

1.5 HP Dust Collector

Model: MDC-502L

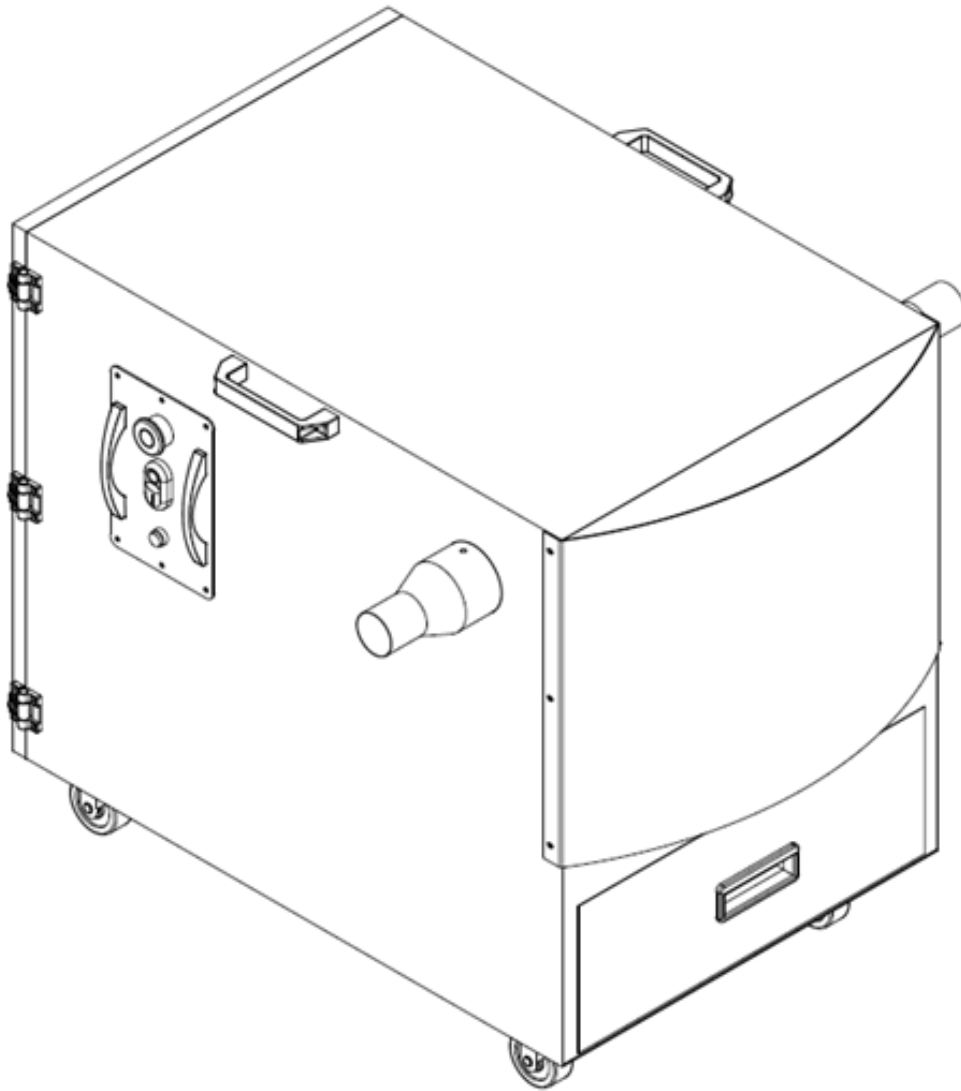

LAGUNA

Laguna Tools
744 Refuge Way
Grand Prairie, TX
lagunatools.com

1.5 HP Dust Collector

Scope of This Manual

This manual outlines the basic procedures for unpacking, installing, and operating the 1.5 HP dust collector.

For detailed instructions and video, please go to www.lagunatools.com

Customer Service

For technical support, please contact Laguna Tools:

Call Customer Service at 1-800-332-4094 or email customer_service@lagunatools.com. Please note the machine type in the subject line.

Copyright © 2023

Laguna Tools, Inc.

ALL RIGHTS RESERVED

This document contains material protected under International and Federal Copyright Laws and Treaties. Any unauthorized reprint or use of this material is prohibited. No part of this document may be reproduced or transmitted in any form or by any means, electronic or mechanical, including photocopying, recording, or by any information storage and retrieval system without express written permission from the author/publisher. LAGUNA® and the LAGUNA Logo® are the registered trademarks of Laguna Tools, Inc.

DISCLAIMER

Laguna Tools is not responsible for errors or omissions. Specifications subject to change. Machines may be shown with optional accessories.

Revision 01 (03/18/2024)

1.5 HP Dust Collector

Table of Contents

| | | |
|------------|--|-----------|
| 1.0 | General Information and Safety | 6 |
| 1.1 | Overview | 6 |
| 1.2 | Safety Signs and Call-Outs | 6 |
| 1.3 | Safety Warnings | 7 |
| 1.4 | Additional Safety Information | 8 |
| 1.5 | Proposition 65 Warning of Harmful Exposure | 10 |
| 2.0 | Specifications and Dimensions..... | 11 |
| 2.1 | Specification Table | 11 |
| 3.0 | Receiving the Machine | 12 |
| 4.0 | Components & Hardware..... | 14 |
| 5.0 | Machine Placement | 18 |
| 5.1 | Placement | 18 |
| 5.2 | Dust Collection | 18 |
| 5.3 | Electrical..... | 18 |
| 5.4 | Lighting..... | 18 |
| 6.0 | Unloading & Unpacking the Machine | 19 |
| 7.0 | Grounding Instructions..... | 21 |
| 7.1 | For Grounded, Cord-Connected Appliances..... | 21 |
| 7.2 | For a Permanently Connected Appliance | 21 |

1.5 HP Dust Collector

| | | |
|------|-------------------------------------|----|
| 8.0 | Assembly and Setup | 22 |
| 9.0 | Exploded Diagram & Parts List | 25 |
| 10.0 | Maintenance..... | 28 |
| 11.0 | Troubleshooting | 29 |
| 12.0 | Warranties | 31 |

1.5 HP Dust Collector

1.0 General Information and Safety

1.1 Overview

SAVE THESE INSTRUCTIONS

Read this manual carefully before assembly, testing and operating. Read and understand all warnings and operation instructions before using any tool or equipment. Always follow basic safety precautions to reduce the risk of personal injury. Improper operation, maintenance, or modification of tools or equipment could result in serious injury or property damage. Laguna Tools equipment is designed for specific and limited applications. This product should neither be modified nor used for any application other than those for which it was designed.

PERSONAL SAFETY IS THE RESPONSIBILITY OF THE OPERATOR.

1.2 Safety Signs and Call-Outs

 **DANGER**

An imminently hazardous situation which, if not avoided, will result in death or serious injury.

 **WARNING**

A potentially hazardous situation which, if not avoided, may result in death or serious injury.

 **CAUTION**

A potentially hazardous situation which, if not avoided, could result in minor or moderate injury.

NOTE

A helpful tip from Laguna Tools staff.

1.5 HP Dust Collector

1.3 Safety Warnings

1. Failure to comply with safety instructions may lead to personal injury and/or damage to the equipment. Do not operate the machine unless familiar with all safety instructions, warnings, and signs.
2. Do not operate the machine with the electrical cabinet door open—High Voltage Supply Inside.
3. The machine must be properly electrically grounded. The power supply must be connected with a permanently fixed electrical wire.
4. Keep children and non-operators away from the machine.
5. Operators must be familiar with the installation, operation, and service of the machine. Only proper operation can ensure the safe and smooth running of the machine.

 **WARNING**

Automated machinery involves moving parts which pose a potential hazard to personnel. Be aware of machine movement at all times.

 **WARNING**

Only allow qualified service personnel to perform electrical installation or repair work, and always disconnect power before accessing or exposing electrical equipment to reduce risks.

 **CAUTION**

Machine bits are sharp and pose a cutting hazard. Do not handle without gloves or while the machine is in operation.

1.5 HP Dust Collector

1.4 Additional Safety Information

1. All motion parameters have been set up by Laguna Tools. If any modifications are required, please have a professional operator perform the changes.
2. Safety Signs should be attached to places that are easy to spot.
3. Use the machine only in clean areas free from excessive moisture or flammable objects.
4. The machine must be level. Level the machine if the ground is uneven.
5. Keep the machine, electrical cabinet, and surrounding area clear of obstructions and free from excessive moisture.
6. Keep the machine, electrical cabinet, and cables away from excessive heat, flammable substances, and sharp objects.
7. Do not attempt to exceed the limits of the machine.
8. NEVER use the dust collector to dissipate fumes or smoke. NEVER pick-up anything that is burning or smoking, such as cigarettes, matches or hot ashes.
9. WARNING: TO REDUCE THE RISK OF ELECTRICAL SHOCK do not use outdoors or on wet surfaces. Use for dry pickup only!
10. Disconnect power to all system components when not in use, when changing accessories, and before servicing. Remove the switch keys or lock-out the machine to prevent unauthorized use and child-proof the workshop.
11. Exercise care with machine controls and around keypad to avoid unintentional start-up.
12. Keep cutting tools clean and sharp.
13. DO NOT use the dust collector to pick up flammable or combustible liquids, such as gasoline. NEVER use the dust collector near any flammable or combustible liquids.
14. Use the dust collector to pick up wood materials only. DO NOT use the dust collector to pick up metal shavings, dust, water, or parts.
15. DO NOT pull the dust collector by the power cord. NEVER allow the power cord to come in contact with sharp edges, hot surfaces, oil or grease.
16. DO NOT unplug the dust collector by pulling on the power cord. ALWAYS grasp the plug, not the cord.
17. REPLACE a damaged cord immediately. DO NOT use a damaged cord or plug. If the dust collector is not operating properly, or has been damaged, left outdoors or has been in contact with water, contact Laguna customer service.

1.5 HP Dust Collector

18. DO NOT use the dust collector without a filter bag and dust collection bag in place and properly secured.
19. DO NOT operate the dust collector with unused dust intake ports uncapped. ALWAYS cover exposed dust intake ports.
20. CONNECT dust collector to a properly grounded outlet only. See Grounding Instructions.
21. Lubricate and change accessories when necessary.
22. Cables and cords should be inspected regularly.
23. Keep controls clean and dry.
24. Keep a copy of this manual for future reference.
25. Perform daily inspection of the machine for damaged, loose, or improperly adjusted parts or any condition that could affect safe operation. For your own safety, do not operate the machine with damaged parts.
26. Stay alert at all times while operating the machine.
27. Always wear safety glasses and hearing protection.
28. Know where the emergency stop switch is located.
29. Never operate machinery under the influence of drugs or alcohol, when tired, or when distracted.
30. Do not wear clothing, apparel, or jewelry that can become entangled in moving parts. Always tie back or cover long hair. Wear non-slip footwear to reduce the risk of slipping and losing control or accidentally contacting cutting tool or moving parts.
31. Never stand on the machine. Serious injury may occur if the machine is tipped or if the cutting tool is unintentionally contacted.
32. Consult the Owner's Manual or Laguna Tools for recommended accessories. Using improper accessories will increase the risk of serious injury or damage.

1.5 HP Dust Collector

1.5 Proposition 65 Warning of Harmful Exposure

Some dust created by power sanding, sawing, grinding, drilling, and other construction activities contains chemicals known to the state of California to cause cancer, birth defects, or other reproductive harm. Some examples of these chemicals are:

- Lead from lead-based paint.
- Crystalline silica from bricks, cement, and other masonry products.
- Arsenic and chromium from chemically treated lumber.



Fire Warning

Use extreme caution when cutting flammable materials such as wood or acrylic. Keep the machine clean by following the supplied maintenance schedule and always have a fire extinguisher ready to extinguish a fire. Take extreme caution when cutting acrylic materials as they are more volatile than other materials.

Never leave the machine running unattended.

The tools sold by Laguna Tools are safe when used properly, as described by the American National Safety Institute, the UL Standards of safe tool use, and the IEC standards of safe tool use. Laguna Tools is in no way responsible for injury or death that occurs while using this product.

The risk of exposure varies depending on frequency of use. To reduce exposure to these chemicals, work in a well-ventilated area and work with approved safety equipment, such as face or dust masks that are specifically designed to filter out microscopic particle

1.5 HP Dust Collector

2.0 Specifications and Dimensions

2.1 Specification Table

Table 2-1: Specification Table

| Specifications | |
|---------------------------------|--|
| AMPERAGE | 10.7 AMP |
| FOOTPRINT (L x W x H) | 33.5" x 32"x 29.5" (850mm x 810mm x 745mm) |
| MOTOR SPEED | 3450 RPM |
| MOTOR | 1.5 HP |
| SUCTION CAPACITY | 490 CFM |
| STATIC PRESSURE | 2.95 Inch H2O |
| IMPELLER SIZE | 11" |
| DUST PORT OUTSIDE DIAMETER | 3" |
| NUMBER OF DUST PORTS | 2 |
| SWITCH | Magnetic Switch |
| NET WEIGHT | 165 lbs (74.5 kgs) |
| GROSS WEIGHT | 185 lbs (84 kgs) |
| CUBIC FEET | 16.1' |
| SHIPPING DIMENSIONS (L x W x H) | 35" x 26" x 31" (885 x 660 x 780mm) |

3.0 Receiving the Machine

Following delivery and before the driver and riggers have left, inspect the packing, invoice, and shipping documents. Next, ensure there is no visible damage to the packaging or the machine. All damage must be noted on the delivery documents and signed by the receiver and the delivery driver. Contact Laguna Tools Customer Service as soon as possible in case of damage. It is advisable to photograph and document any shipping damage. The original packaging is required to return damaged equipment to Laguna Tools.

NOTE

Sawdust may be found in the machine upon arrival. This is because the machine has been tested prior to shipment from the factory and/or Laguna Tools. Laguna Tools tests all machines prior to shipping, but some adjustments may have to be undertaken by the customer. These adjustments are covered in the various sections of this manual.

Most large machinery will be delivered on a tractor trailer 48 to 53 feet long. Please notify a Sales Representative with any Delivery Restrictions. The customer is required to have a forklift (6000 lbs. or larger is recommended) with 72-inch forks or fork extensions.

4.0 Components & Hardware

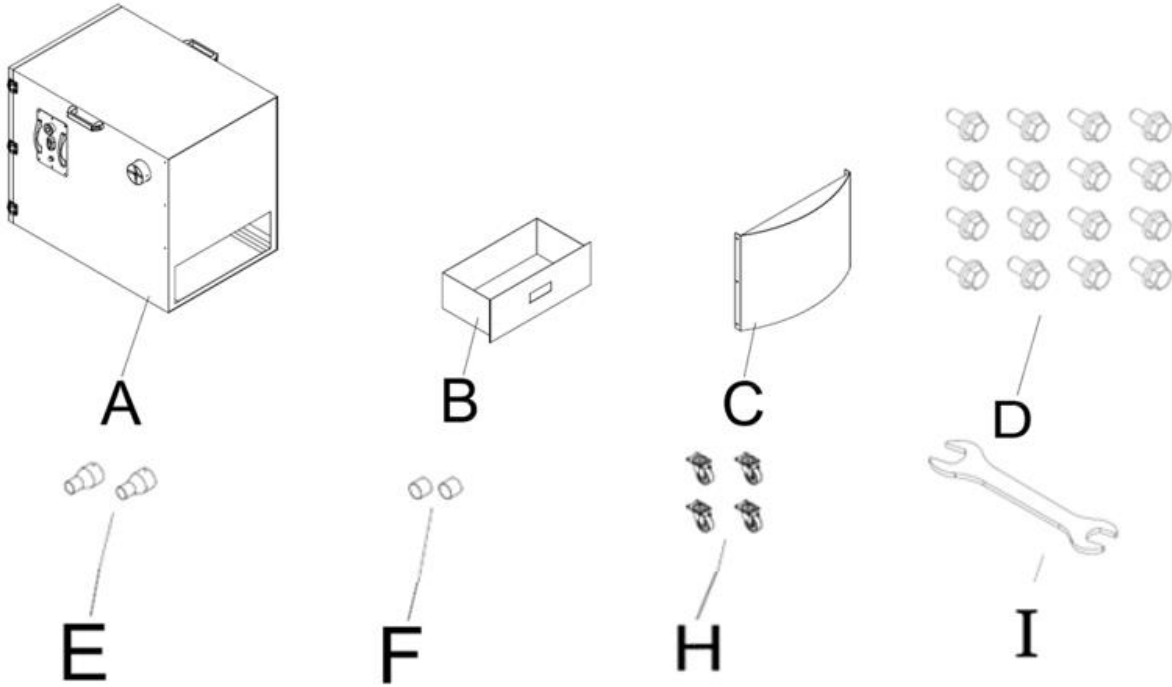

Figure 4-1: Components & Hardware

1.5 HP Dust Collector

| NO. | DESCRIPTION | QUANTITY |
|-----|----------------------|----------|
| A | Main Housing | 1 |
| B | Drawer | 1 |
| C | Main Housing Cover | 1 |
| D | Flange Bolts | 16 |
| E | Hose Adapters | 2 |
| F | Adapter Cover | 2 |
| G | Main Cabinet Casters | 4 |
| H | Open Wrench | 1 |

1.5 HP Dust Collector

NOTES:

5.0 Machine Placement

When unpacking the machine, separate all enclosed items from the packing materials and inspect each for damage. Save the packaging materials until all issues concerning missing or damaged items have been resolved.

5.1 Placement

Select the area where the machine will be operated. The physical environment where the machine is located is important to safe assembly and operation. Before removing the machine from its packaging consider the weight load, electrical installation requirements, lighting, dust collection, and space allocation available for the machine and accompanying materials.

Guidelines for properly placing the machine follow:

1. There should be sufficient area around the machine to facilitate easy access to the workpiece, perform maintenance, and provide safe egress in the event of an emergency.
2. Select a solid level floor rated to hold the weight of the machine and workpieces under both static and dynamic loads. Laguna Tools recommends concrete flooring. Consult a licensed and experienced professional if in doubt.
3. Locate the machine close to a power source and dust collection.
4. Allow an area for the storage of workpiece materials, finished products, and tools.
5. Leave ample space around the machine for the operator to handle both the equipment and the materials being cut.
6. Leave enough space around the machine to open or remove doors/covers as required by the maintenance described in the Owner's Manual.
7. **DO NOT** place or operate the machine in a highly magnetic area.

5.2 Dust Collection

Allow enough space for proper dust collection from the machine. For optimal operation, ensure that the machine is in a dry environment, free from excessive moisture, extreme weather conditions, hazardous chemicals, or airborne abrasives

5.3 Electrical

The machine requires permanent, direct power installed by a qualified electrician familiar with industrial best practices. Ensure that all power cords are protected from traffic, moisture, chemicals, or other hazards. For safety, always have a qualified electrician assess grounding and any further electrical needs.

5.4 Lighting

Ensure that the lighting your machine is placed under is sufficient to safely perform regular operation and maintenance. Any glares, shadows, or strobe lighting which may distract or prevent the operator from safely operating the machinery should be removed from the working area.

1.5 HP Dust Collector

6.0 Unloading & Unpacking the Machine

NOTE

All shipping related claims for loss or damaged goods must be made to Laguna Tools within 24 hours of delivery.

Contact Laguna Tools customer service department to make claims for any damaged items/parts.

The original packaging is required to return damaged goods within the warranty period.

The machine should be delivered on a trailer by one or a combination of these methods:

1. In a crate
2. In a box
3. Heat shrunk in plastic
4. Sitting on a pallet

BEFORE unpacking your new machine, inspect the packaging, invoice, and the shipping documents supplied by the driver. When unpacking the machine, verify there are no signs of damage to the parts or machine you have received.

See the components section to cross reference the parts you should receive.

WARNING

The customer is required to have a forklift (6000 lbs. or larger is recommended) with 72-inch forks or fork extensions.

WARNING

Unload the machine with care. DO NOT pinch, crush, or damage any components that are on/around the machine.

1.5 HP Dust Collector

WARNING

This machine is heavy. Seek assistance from an experienced professional if you have any doubt about the following unboxing or set up procedures.

DO NOT attempt any procedure that you feel is unsafe or you believe you do not have the physical capability of achieving.

CAUTION

When determining location, verify there is sufficient room around the machine.. If you cannot fully open all the doors around the machine, it cannot be installed or serviced in the future if necessary.

Tools needed:

- Crowbar or prybar
- Forklift or pallet jack
- Drill with Phillips head bit
- Tip snips

BEFORE moving the machine to the desired location, verify that there is sufficient room around the dust collector to facilitate easy access to the workpiece, perform maintenance, and provide a safe exit in the event of an emergency.

1. Use a forklift (6000 lbs. or larger is recommended) with 72-inch forks or fork extensions to unload the machine from the trailer.
2. Move the machine to a desired location.
3. Use tin snips to cut and remove any straps.
4. Use a drill with Phillips head bit to remove any screws that are securing the machine to the pallet/crate.
5. If necessary, use the prybar to remove any surrounding wood.
6. Use the forklift to lift the machine and remove the pallet/crate.
7. Lower the machine gently on the floor.
8. Ensure that all parts/components are present and in good condition.

7.0 Grounding Instructions

The appliance must be grounded, if it should malfunction or breakdown, grounding provides a path of least resistance for electric current to reduce the risk of electric shock. This appliance is equipped with a cord having equipment-ground conductor and grounding plug. The plug must be inserted into an appropriate outlet that is properly installed and grounded in accordance with all local codes and ordinances.

WARNING

Improper connection of the equipment-grounding conductor can result in a risk of electric shock. Check with a qualified electrician or service person if you are in doubt as to whether the outlet is properly grounded. Do not modify the plug provided with the appliance – if it will not fit the outlet; have a proper outlet installed by a qualified electrician.

7.1 For Grounded, Cord-Connected Appliances

This appliance is for use on a circuit having a normal rating more than 120 volt and is factory-equipped with a specific electric cord and plug to permit connection to a proper electric circuit. Make sure that the appliance is connected to an outlet having the same configuration as the plug. No adaptor should be used with this appliance. If the appliance must be reconnected for use on a different type of electric circuit, qualified service personnel should make the reconnection.

7.2 For a Permanently Connected Appliance

This appliance must be connected to a grounded metal, permanent wiring system; or an equipment-grounding conductor must be run with the circuit conductors and connected to the equipment grounding terminal or lead on the appliance.

1.5 HP Dust Collector

8.0 Assembly and Setup

WARNING

Do not connect to a power supply until set-up is complete. Do not perform any of the following steps, installations, or adjustments with the machine connected to a power source unless directed to do so.

Tools & items needed:

- *Knife or cutting tool*
 - *Tin snips*
 - *Forklift (6000 lbs. or larger is recommended)*
1. After unloading the machine, make sure that all straps, plastic wrap, and surrounding wood are removed.
 2. Use a forklift to remove the control cabinet from the machine.

CAUTION

Be cautious of the cords running from the electrical cabinet to the machine.

DO NOT rip or fray them when removing the electrical cabinet.

CAUTION

The vacuum pump is heavy and requires a forklift to move.

3. Use the forklift to remove the vacuum pump(s) from the table.
4. Remove any other components from the machine and set them to the side.

1.5 HP Dust Collector

NOTE

All shipping related claims for loss or damaged goods must be made to Laguna Tools within 24 hours of delivery.

Contact Laguna Tools customer service department to make claims for any damaged items/parts.

The original packaging is required to return damaged goods within the warranty period.

1. Turn the main housing (NO.33) upside down.
2. Install the casters (NO.32) onto the four corners of the main housing and secure each caster by tightening the flange bolts(NO.31 with the supplied wrench.
3. Carefully place the cabinet on its casters.

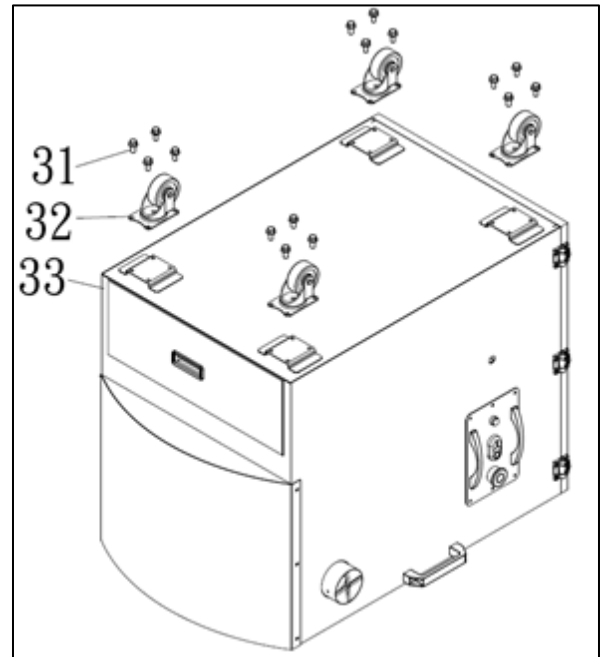

Figure 8-1: Caster Installation

1.5 HP Dust Collector

- Place the hose adaptors (NO.38) over the ports and use a Phillip head screwdriver to tighten the screw (NO.37) onto the main housing (NO.33).

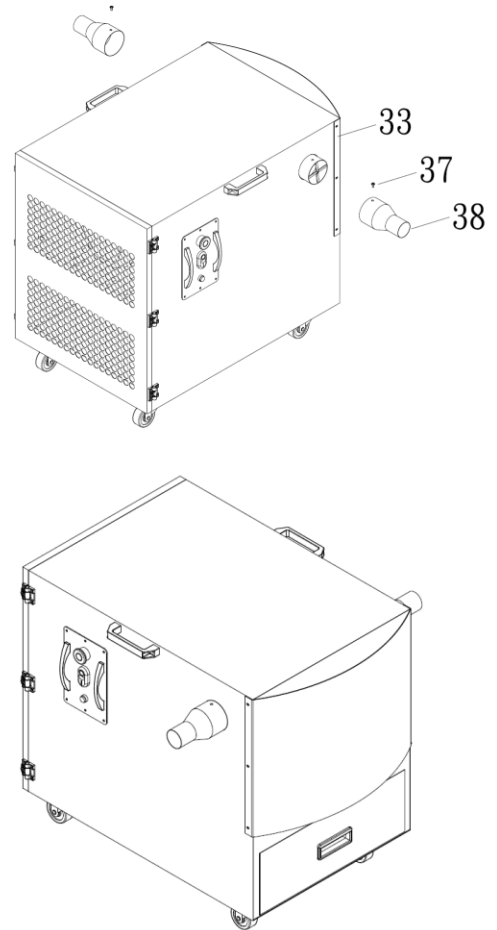
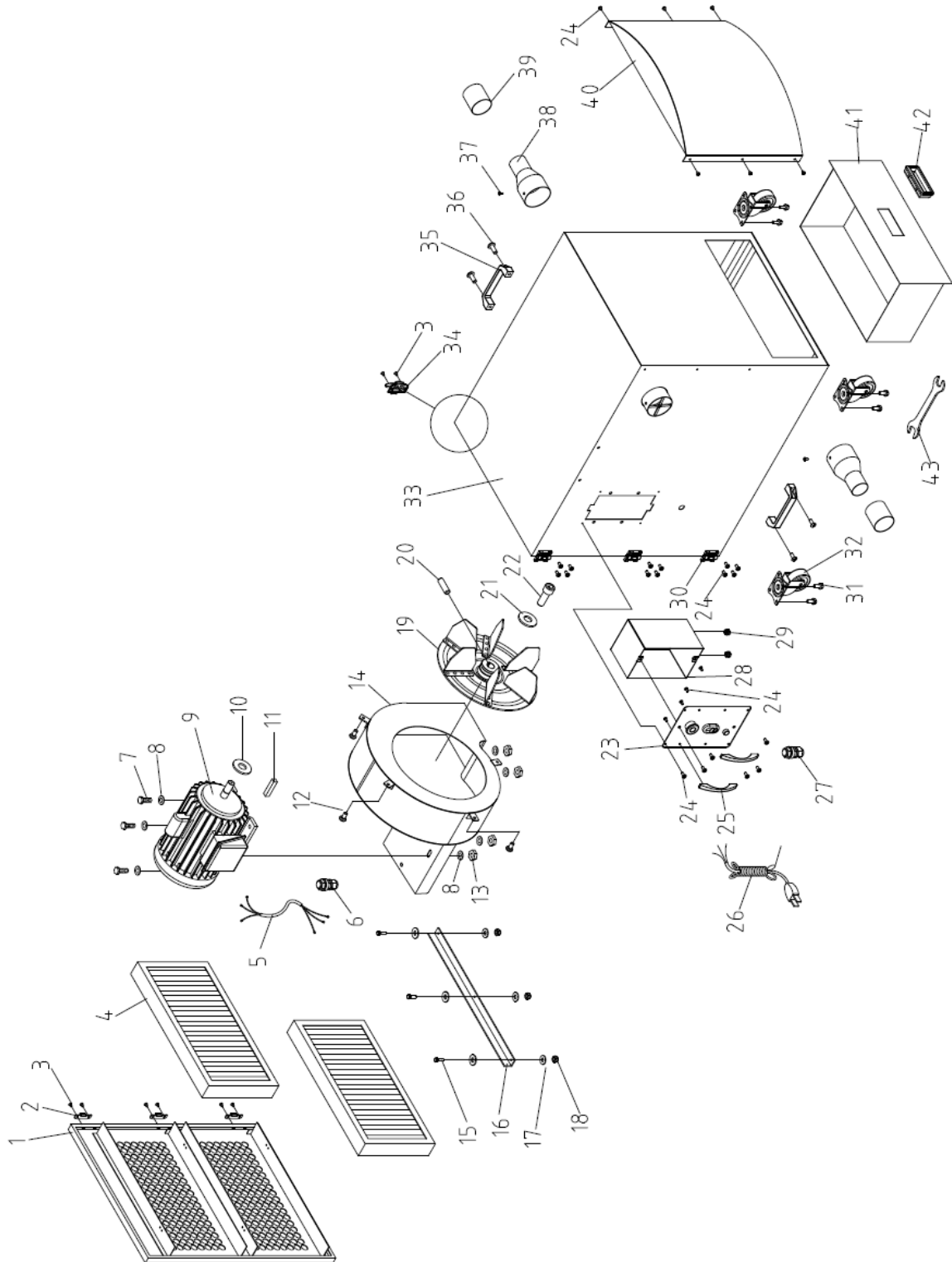

Figure 8-2: Hose Adaptor Installation

- Assembly is complete.

1.5 HP Dust Collector

9.0 Exploded Diagram & Parts List



1.5 HP Dust Collector

| NO. | DESCRIPTION | SPECIFICATION | QUANTITY |
|-----|---------------------------------|---------------|----------|
| 1 | Front Cover | | 1 |
| 2 | Hook base | | 3 |
| 3 | Countersunk Phillips Head Screw | M4*8 | 12 |
| 4 | Filters | | 2 |
| 5 | Motor Cord | | 1 |
| 6 | Bushing | PGB 13.5-12B | 1 |
| 7 | Hex Cap Screw | 5/16"*3/4" | 4 |
| 8 | Flat Washer | 5/16"*23*2 | 8 |
| 9 | Motor | 1.5HP/110V | 1 |
| 10 | Motor Packing | | 1 |
| 11 | Key | 6*6*25 | 1 |
| 12 | Phillips Head Screw | 1/4"*1/2" | 4 |
| 13 | Hex Nut | 5/16" | 4 |
| 14 | Housing | | 1 |
| 15 | Hex. Head Bolts | M6*20 | 3 |
| 16 | Motor Plate Bar | | 1 |
| 17 | Washer | 1/4"x16x1.5 | 6 |
| 18 | Lock Nut | M6 | 3 |
| 19 | Impeller | 11" | 1 |
| 20 | Hex Cap Screw | 5/16"*5/16" | 1 |
| 21 | Washer | | 1 |

1.5 HP Dust Collector

| | | | |
|----|------------------------|------------|----|
| 22 | Socket Head Cap Screw | M6*20 | 1 |
| 23 | Switch Plate | | 1 |
| 24 | Phillips Head Screw | M4*12 | 22 |
| 25 | Panel Handle | | 2 |
| 26 | Power Cord | | 1 |
| 27 | Bushing | M16-10B | 1 |
| 28 | Control Box Assembly | | 1 |
| 29 | Power Cord Buckle | SB8R-1 | 2 |
| 30 | Plastic Hinge | | 3 |
| 31 | Flange Bolt | 5/16"*1/2" | 16 |
| 32 | Main Cabinet Casters | 2-1/2" | 4 |
| 33 | Main Collector Cabinet | | 1 |
| 34 | Swivel Buckle | | 3 |
| 35 | Handle | | 2 |
| 36 | Flat Head Screw | 1/4"*1/2" | 4 |
| 37 | Phillips Head Screw | 3/16"*3/8" | 2 |
| 38 | Hose Adaptor | 3"x2" | 2 |
| 39 | Main Housing Cover | | 1 |
| 40 | Debris Drawer | | 1 |
| 41 | Drawer Handle | | 1 |
| 42 | Open End Wrench | 10x12 | 1 |

1.5 HP Dust Collector

10.0 Maintenance

The SmartShop Auto Loader requires the operator to perform basic regular maintenance to ensure the normal operation of the equipment, reduce possible failures, and prolong the service life of the equipment. Follow this maintenance table to ensure proper use of the machine.

Table 10-1: Maintenance Table

| Daily | Weekly | Monthly | Every three Months | Every six Months | Yearly |
|---|--------|---------|--------------------|------------------|--------|
| Inspect the machine for damage and loose or worn parts | | | | | |
| Verify the electrical connections are fitted tightly and correctly. | | | | | |
| Verify that all electrical connections are not damaged or worn. | | | | | |
| Clean surface dust | | | | | |

1.5 HP Dust Collector

11.0 Troubleshooting

Table 11-1: Troubleshooting Table

| Symptom | Possible Cause | Possible Solution |
|--|---|---|
| Machine does not start or a breaker trips. | Power supply switched OFF or is faulty. | Ensure power supply is ON and has the correct voltage. |
| | Wall fuse/circuit breaker is blown/tripped. | Ensure adequate circuit size; install inlet restrictor, replace weak breaker. |
| | Incorrectly wired motor connection. | Rewire or call certified service technician or electrician. |
| | On-board circuit breaker is tripped. | Allow motor to cool, improve ventilation, press reset button. |
| | Wiring is open/has high resistance. | Check for broken wires or poor connections, repair, as necessary. |
| | Faulty power switch. | Replace switch. |
| | Motor is at fault. | Test/repair/replace. |
| Excessive vibration or noise during operation. | Loose component. | Inspect and tighten all bolts/nuts. |
| | Loose or broken motor mount. | Tighten or replace as needed. |
| | Motor fan hitting fan cover. | |

1.5 HP Dust Collector

| | | |
|---|--|---|
| | <p>Bad motor bearings.</p> | <p>Check fan and cover; replace as needed.</p> <p>Rotate shaft manually, check for grinding or loose shaft, replace bearings if needed.</p> |
| <p>Loud, repetitive noise, or excessive vibration coming from cyclone</p> | <p>Machine is on uneven surface.</p> <p>Damaged/Unbalanced impeller.</p> <p>Loose connections.</p> <p>Impeller is loose.</p> <p>Motor fan hitting fan cover.</p> | <p>Stabilize on a flat surface.</p> <p>Inspect impeller for dents, bends, loose fins. Replace if needed.</p> <p>Check and re-tighten all fasteners.</p> <p>Replace the motor and impeller.</p> <p>Check fan and cover; replace as needed.</p> |

1.5 HP Dust Collector

12.0 Warranties

CNC Limited Warranty

New CNC machines sold by Laguna Tools carry a one-year warranty effective from the date of shipping. Laguna Tools guarantees all new machines sold to be free of manufacturers' defective workmanship, parts, and materials. We will repair or replace, without charge, any parts determined by Laguna Tools, Inc. to be a manufacturer's defect. If the defective item/part is determined to be damaged due to lack of maintenance, cleaning or misuse/abuse, the customer will be responsible for the cost to replace the item/part, plus all related shipping charges. This limited warranty does not apply to natural disasters, acts of terrorism, normal wear and tear, product failure due to lack of maintenance or cleaning, damage caused by accident, neglect, lack of or inadequate dust collection, misuse/abuse or damage caused where repair or alterations have been made or attempted by others.

No Modifications Allowed or Sold

Laguna Tools, Inc. is not responsible for additional tools or modifications sold or performed (other than from/by Laguna Tools, Inc.) on any Laguna Tools, Inc. woodworking machine. Warranty may be voided upon the addition of such described tools and/or modifications, determined on a case-by-case basis. Software purchased through Laguna Tools, Inc., is not covered under this warranty and all technical support must be managed through the software provider. Normal user alignment, adjustment, tuning, and machine settings are not covered by this warranty. It is the responsibility of the user to understand basic woodworking machinery settings and procedures and to properly maintain the equipment in accordance with the standards provided by the manufacturer.

Parts under warranty are shipped at Laguna Tools, Inc.'s cost either by common carrier, FEDEX ground service, or a similar method. Technical support to install replacement parts is primarily provided by phone, fax, e-mail or Laguna Tools Customer Support Website. The labor required to install replacement parts is the responsibility of the user. Laguna Tools is not responsible for damage or loss caused by a freight company or other circumstances not in our control. All claims for loss or damaged goods must be notified to Laguna Tools within twenty-four (24) hours of delivery.

Please contact our Customer Service Department for more information. Only NEW machines sold to the original owner are covered by this warranty.

For warranty repair information, call 1-800-332-4094.

Warning: No portion of these materials may be reproduced without written approval from Laguna Tools, Inc.

Copyright 2023 Laguna Tools, Inc.

1.5 HP Dust Collector

Laguna Tools Warranty

WARRANTY & REGISTRATION

THANK YOU!

Welcome to the Laguna Tools® group of discriminating woodworkers. We understand that you have a choice of where to purchase your machines and appreciate the confidence you have in the Laguna Tools® brand.

Through hands-on experience, Laguna Tools® is constantly working hard to make innovative, precision products. Products that inspire you to create works of art, are a joy to operate, and encourage your best work.

Laguna Tools®
Imagination, Innovation, and Invention at Work

WARRANTY & REGISTRATION

Every product sold is warranted to be free of manufacturers' defective workmanship, parts, and materials. For any questions about this product, the intended use or what it was designed for, customer service, or replacement parts, please contact our customer service department:

Laguna Tools® Customer Service
744 Refuge Way, Grand Prairie, Texas 75050, USA
1-800-234-1976
customerservice@lagunatools.com
www.lagunatools.com/why/customer-service/
8AM to 5PM PST, Monday through Friday

For warranty claims or to report damage upon receiving – please reach out to our warranty department:

Laguna Tools® Warranty Service
744 Refuge Way, Grand Prairie, Texas 75050, USA
1-800-332-4049
customerservice@lagunatools.com
www.lagunatools.com/policies/warranty
8AM to 5PM PST, Monday through Friday

REGISTRATION

To prevent voiding this warranty, all products sold must be registered within thirty (30) days of receiving the product. Registering the product will enable the original purchaser to receive notifications about important product changes, receive customer service, and be able to file a warranty claim against defective workmanship, parts, or materials.



WHO IS COVERED

The applicable warranty covers only the initial purchaser of the product from the date of receiving the product. To file such claims, the original purchaser must present the original receipt as proof of purchase.

WHAT IS COVERED

The warranty covers any defects in the workmanship of all parts and materials that make up the machine unless otherwise specified. Any part, determined by Laguna Tools®, to have a defect will be repaired or replaced (and shipped), without charge. The defective item/part must be returned to Laguna Tools® with the complaint and proof of purchase in the original packaging that it was received in. In the event the item/part is determined to be not covered by this warranty, the customer will be responsible for the cost to replace the item/part and all related shipping charges.

WARRANTY LIMITATIONS

This limited warranty does not apply to natural disasters, acts of terrorism, normal wear and tear, product failure due to lack of maintenance or cleaning, damage caused by accident, neglect, or lack-of inadequate dust collection. The warranty may be voided against proof of misuse/abuse, damage caused where repair or alterations have been made or attempted by others, using the product for purposes other than those described as intended use (unless with consent by Laguna Tools®), modification to the product, or use with an accessory that was not designed for the product. It is the responsibility of the user to understand basic woodworking machinery settings and procedures and to properly maintain the equipment in accordance with the standards provided in this manual.

LENGTH OF WARRANTY

All new machines and optional accessories sold through an authorized dealer carry a two-year warranty effective the date of receiving the product. Machines sold for either commercial or industrial use have a one-year warranty. Wearable parts like throat plates, bandsaw guides, etc., have a ninety-day warranty.

Table A-1 Warranty Lengths

| |
|---|
| 2 Year – New Machines Sold Through an Authorized Dealer |
| 2 Year – Accessories Sold as Machine Options (excluding blades) |
| 1 Year – Machines Sold for Commercial or Industrial Use |
| 1 Year – Blades and Accessories outside of Machine Options |
| 90 Days – Wearable Parts |

Aside from being free of defects upon receiving, consumable parts, like cutters and abrasives, are not covered by this warranty unless otherwise stated by Laguna Tools®. These parts are designed to be used at the expense of the operator and are available for replacement or inventory purchase. The determination of a consumable part will be made on a case-by-case basis by Laguna Tools®.

SHIPPING DAMAGE

Laguna Tools® is not responsible for damage or loss caused by a freight company or other circumstances not in the direct control of Laguna Tools®. All shipping-related claims for loss or damage goods must be made to Laguna Tools within twenty-four hours of delivery.

HOW TO RECEIVE SUPPORT

To file a warranty-claim please contact the warranty department at 1-800-234-1976. To receive customer service or technical support please contact the customer service department at 1-800-332-4049. Parts, under warranty, are shipped at the expense of Laguna Tools® either by common carrier, FedEx ground services or similar method. Technical support to install replacement parts is primarily provided by phone, fax, email, or the Laguna Tools Customer Support Website.



© 03/2018, Laguna Tools, Inc.

LAGUNA

Laguna Tools, Inc.

744 Refuge Way

Grand Prairie, TX 75050

800-234-1976

www.lagunatools.com

Copyright © 2023 Laguna Tools, Inc. All rights reserved.