

TIFLUX:5

Owner's Manual



5HP CYCLONE
AUTO CLEAN TIMING SYSTEM



LAGUNA



Thank you for investing in a Laguna Tools TFLUX5 dust collector. These dust collectors are a part of a family of unique machines proudly offered by Laguna Tools. Every Laguna machine is engineered for years of dependable service. Please feel free to contact Laguna Tools if you have a question or suggestion. We appreciate working with you and your choice of a Laguna Tools machine for your shop.

Regards,
Torben Helshoj
President & Founder Laguna Tools

This manual applies to the TFLUX5 dust collector. Enter the model number and serial number below for quick reference when ordering accessories, supplies or parts.

Model: _____ Date of purchase: _____

Serial: _____ Place of purchase: _____

LATEST MANUAL:

Below is a QR code which will direct you to the industrial machine reference page, your machine and the latest version of the manual is located on the Laguna Tools website. The online manual may have updates and information added after the printed copy was released. Scan the code with your smartphone or copy the URL link to be directed to the latest manual page to reference your specific machine and model.

<https://lagunatools.com/resources/product-manuals/#industrial>



Laguna Tools 744 Refuge Way, Suite 200
Grand Prairie TX 75050

800-234-1976

www.lagunatools.com



TABLE OF CONTENTS

Important Safety Instructions	4
Safety Guidelines - Definitions	7
General Safety Rules	7
Additional Safety for Dust Collectors	8
Power Connections & Wiring Diagram	10
Motor Specifications	11
Grounding Instructions	11
Control Panel & Remote Control	12
Specifications	13
Unpacking	14
Assembly	15
Cleaning Filter	34
Emptying	37
Routine Inspection	38
Trouble Shooting	39
Exploded View	41
Parts list	42
Warranty	49



IMPORTANT SAFETY INSTRUCTIONS

▲WARNING

READ AND UNDERSTAND ALL WARNINGS AND OPERATING INSTRUCTIONS BEFORE USING THIS EQUIPMENT. Failure to follow all instructions listed below, may result in electric shock, fire, and/or serious personal injury or property damage.

Woodworking can be dangerous if safe and proper operating procedures are not followed. As with all machinery, there are certain hazards involved with the operation of the product. Using the machine with respect and caution will considerably lessen the possibility of personal injury. However, if normal safety precautions are overlooked or ignored, personal injury to the operator may result. Safety equipment such as guards, push sticks, hold-downs, featherboards, goggles, dust masks and hearing protection can reduce your potential for injury. But even the best guard won't make up for poor judgment, carelessness or inattention. **Always use common sense** and exercise caution in the workshop. If a procedure feels dangerous, don't try it. Figure out an alternative procedure that feels safer. **REMEMBER:** Your personal safety is your responsibility.

▲WARNING

This machine was designed for certain applications only. We strongly recommend that this machine not be modified and/or used for any application other than that for which it was designed. If you have any questions relative to a particular application, DO NOT use the machine until you have first contacted the manufacturer to determine if it can or should be performed on the product.

If you have any questions relative to its application DO NOT use the product until you have contacted the manufacturer and we have advised you.

When using an electrical appliance, basic precautions should always be followed, including the following:

READ ALL INSTRUCTIONS BEFORE USING (THIS APPLIANCE)

▲WARNING

To reduce the risk of fire, electric shock, or injury:

1. Do not leave appliance when plugged in. Unplug from outlet when not in use and before servicing.
2. Do not use outdoors or on wet surfaces
3. Do not allow to be used as a toy. Close attention is necessary when used by or near children.
4. Use only as described in this manual. Use only manufacturer's recommended attachments.



5. Do not use with damaged cord or plug. If appliance is not working as it should, has been dropped, damaged, left outdoors, or dropped into water, return it to a service center.
6. Do not pull or carry by cord, use cord as a handle, close a door on cord, or pull cord around sharp edges or corners. Do not run appliance over cord. Keep cord away from heated surfaces.
7. Do not unplug by pulling on cord. To unplug, grasp the plug, not the cord.
8. Do not handle plug or appliance with wet hands.
9. Do not put any object into openings. Do not use with any opening blocked; keep free of dust, lint, hair, and anything that may reduce air flow.
10. Keep hair, loose clothing, fingers, and all parts of body away from openings and moving parts.
11. Turn off all controls before unplugging.
12. Use extra care when cleaning on stairs.
13. Do not use to pick up flammable or combustible liquids, such as gasoline, or use in areas where they may be present.
14. Connect to a properly grounded outlet only. See Grounding Instructions.

SAVE THESE INSTRUCTIONS

1. Read and understand the warnings posted on the machine and in this manual. Failure to comply with all of these warnings may cause serious injury.
2. Replace the warning labels if they become obscured or removed.
3. This Cyclone Dust Collector is designed and intended for use by properly trained and experienced personnel only. If you are not familiar with the proper and safe operation of this type of dust collector, do not use until proper training and knowledge have been obtained.
4. Do not use this machine for other than its intended use. If used for other purposes, **LAGUNA TOOLS INC.**, disclaims any real or implied warranty and holds itself harmless from any injury that may result from that use.
5. Always wear approved safety glasses/face shields while using this machine.
6. Before operating this dust collector, remove tie, rings, watches and other jewelry, and roll sleeves up past the elbows. Remove all loose clothing and confine long hair. Non-slip footwear or anti-skid floor strips are recommended. Do **not** wear gloves.
7. Wear ear protectors (plugs or muffs) during extended periods of operation.

Proposition 65 Warning

8. Some dust created by power sanding, sawing, grinding, drilling and other construction activities contain chemicals known to cause cancer, birth defects or other reproductive harm. Some examples of these chemicals are:
 - Lead from lead based paint.
 - Crystalline silica from bricks, cement and other masonry products.
 - Arsenic and chromium from chemically treated lumber.

(cont.)



Your risk of exposure varies, depending on how often you do this type of work. To reduce your exposure to these chemicals, work in a well-ventilated area and work with approved safety equipment, such as face or dust masks that are specifically designed to filter out microscopic particles.

9. Do not operate this machine while tired or under the influence of drugs, alcohol or any medication.
 10. Make certain the switch is in the **OFF** position before connecting the machine to the power source.
 11. Make certain the machine is properly grounded.
 12. Make all machine adjustments or maintenance with the machine unplugged from the power source.
 13. Form a habit of checking to see that all extra equipment such as adjusting keys, wrenches, scrap, stock, and cleaning rags are removed away from the machine before turning on.
 14. Keep safety guards in place at all times when the machine is in use. If removed for maintenance purposes, use extreme caution and replace the guards immediately when maintenance is complete.
 15. Make sure the dust collector is on a flat even surface and the wheels locked in place before use.
 16. Check damaged parts. Before further use of the machine, a guard or other part that is damaged should be carefully checked to determine that it will operate properly and perform its intended function. Check for alignment of moving parts, binding of moving parts, breakage of parts, mounting and any other conditions that may affect its operation. A guard or other part that is damaged should be properly repaired or replaced.
 17. Provide for adequate space surrounding work area and non-glare, overhead lighting.
 18. Keep the floor around the machine clean and free of scrap material, oil and grease.
 19. Keep visitors a safe distance from the work area. **Keep children away.**
 20. Make your workshop child proof with padlocks, master switches or by removing starter keys.
 21. Give your work undivided attention. Looking around, carrying on a conversation and "horse-play" are careless acts that can result in serious injury.
 22. Maintain a balanced stance at all times so that you do not fall or lean against the dust collector. Do not overreach or use excessive force to perform any machine operation.
 23. Use the right tool at the correct speed and feed rate. Do not force a tool or attachment to do a job for which it was not designed. The right tool will do the job better and safer.
 24. Use recommended accessories; improper accessories may be hazardous.
 25. Maintain machinery with care. Follow instructions for lubricating and changing accessories.
 26. Turn off the machine before cleaning. Use a brush or compressed air to remove dust or debris — do not use your hands.
 27. Do not stand on the machine. Serious injury could occur if the machine tips over.
- (cont.)

LAGUNA

28. Never leave the machine running unattended. Turn the power off and do not leave the machine until it comes to a complete stop.
29. Never operate or run the machine without closing the drum up against the lid. Failure to do so will result in the machine amperage increasing and may trip your circuit.

Familiarize yourself with the following safety notices used in this manual:

SAFETY GUIDELINES - DEFINITIONS

This manual contains information that is important for you to know and understand. This information relates to protecting YOUR SAFETY and PREVENTING EQUIPMENT PROBLEMS. To help you recognize this information, we use the symbols below. Please read the manual and pay attention to these sections.



Indicates an imminently hazardous situation which, if not avoided, will result in death or serious injury.



Indicates a potentially hazardous situation which, if not avoided, could result in death or serious injury.



Indicates a potentially hazardous situation which, if not avoided, may result in minor or moderate injury.



Used without the safety alert symbol indicates potentially hazardous situation which, if not avoided, may result in property damage.

GENERAL SAFETY RULES



WARNING FAILURE TO FOLLOW THESE RULES MAY RESULT IN SERIOUS PERSONAL INJURY.

FOR YOUR OWN SAFETY, READ AND UNDERSTAND THE INSTRUCTION MANUAL BEFORE OPERATING THE MACHINE. Learn the unit's application and limitations as well as the specific hazards peculiar to it.



KEEP WORK AREA CLEAN. Cluttered areas and benches invite accidents.

DON'T USE IN DANGEROUS ENVIRONMENT. Don't use this unit in damp or wet locations, or expose it to rain. Keep work area well-lighted.

KEEP CHILDREN AND VISITORS AWAY. All children and visitors should be kept a safe distance from work area.

DISCONNECT UNIT before servicing.

CHECK DAMAGED PARTS. Before further use of the unit, properly repair or replace any part that is damaged.

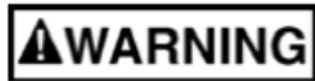

FAILURE TO FOLLOW THESE RULES MAY RESULT IN SERIOUS INJURY.

ADDITIONAL SAFETY FOR DUST COLLECTORS

Intended use. This dust collector is only intended for collecting wood dust and chips from woodworking machines. Do not use this dust collector to collect metal, dirt, pebbles, drywall, asbestos, lead paint, silica, liquids, aerosols, or any flammable, combustible, or hazardous materials.

Hazardous dust. Dust created while using machinery may cause cancer, birth defects, or long-term respiratory damage. Be aware of dust hazards associated with each work piece material, and always wear a NIOSH-approved respirator to reduce your risk.

Dust allergies. Dust from certain woods may cause an allergic reaction in people and animals.

Make sure you know what type of wood dust you will be exposed to in case there is a possibility of an allergic reaction.

Wear respirator. Fine dust that is too small to be caught in the filter will be blown into the ambient air during operation. Always wear a NIOSH-approved respirator during operation and for a short time after to reduce your risk of permanent respiratory damage.

Emptying dust. When emptying dust from the collection container, wear a respirator and safety glasses. Empty dust away from ignition sources and into an approved container.

Disconnecting power supply. Turn the switch off, disconnect the dust collector from the power supply, and allow the impeller to come to a complete stop before leaving the machine unattended or doing any service, cleaning, maintenance, or adjustments.

LAGUNA

Suspended dust particles and ignition sources. Do not operate the dust collector in areas where explosion risks are high. Areas of high risk include, but are not limited to, areas near pilot lights, open flames, or other ignition sources.

Fire suppression. Only operate the dust collector in locations that contain a fire suppression system or have a fire extinguisher nearby.

Impeller hazards. Do not place your hands or tools near the open inlet during operation for any reason. The powerful suction could easily cause accidental contact with the impeller, which will cause serious personal injury or damage to the machine. Always keep small animals and children away from open dust collection inlets.

Avoiding sparks. Do not allow steel or rocks to strike the impeller—this may produce sparks. Sparks can smolder in wood dust for a long time before a fire is detected. If you accidentally cut into wood containing tramp metal (nails, staples, spikes, etc.), immediately turn **off** the dust collector, disconnect it from power, and wait for the impeller to stop—then empty the collection container into an approved airtight metal container.

Operating location. To reduce respiratory exposure to fine dust, locate permanently installed dust collectors away from the working area, or in another room that is equipped with a smoke detector. Do not operate the dust collector in rainy or wet locations—exposure to water may create a shock hazard or decrease the life of the machine.

Static electricity. Plastic dust lines generate high amounts of static electricity as dust chips pass through them. Although rare, sparks caused by static electricity can cause explosions or fire. To reduce this risk, make sure all dust lines are thoroughly grounded by using a grounding wire.

Regular cleaning. Regularly check/empty the collection bags or drum to avoid the buildup of fine dust that can increase the risk of fire. Make sure to regularly clean the surrounding area where the machine is operated—excessive dust buildup on overhead lights, heaters, electrical panels, or other heat sources will increase the risk of fire.



This means that if precautions are not heeded, it may result in minor injury and/or possible machine damage.



This means that if precautions are not heeded, it may result in serious injury or possibly even death.

LAGUNA



DO NOT EXPOSE THE MACHINE TO RAIN OR OPERATE THE MACHINE IN DAMP LOCATIONS.

MOTOR SPECIFICATIONS

Your machine is wired for 220 volts, 60 HZ alternating current. Before connecting the machine to the power source, make sure the switch is in the "OFF" position.

GROUNDING INSTRUCTIONS



THIS MACHINE MUST BE GROUNDED WHILE IN USE TO PROTECT THE OPERATOR FROM ELECTRIC SHOCK.

1. This appliance must be connected to a grounded metal, permanent wiring system; or an equipment-grounding conductor must be run with the circuit conductors and connected to the equipment-grounding terminal or lead on the appliance.

The installer, such as a qualified electrician, cut (or bend over) and insulate the grounding conductor from a field wiring supply cable.

In the event of certain types of malfunctions or breakdowns, grounding provides a path of least resistance for electric current—in order to reduce the risk of electric shock.

Improper connection of the equipment-grounding wire can result in a risk of electric shock. The wire with green insulation (with or without yellow stripes) is the equipment-grounding wire. If repair or replacement of the power cord or plug is necessary, do not connect the equipment-grounding wire to a live (current carrying) terminal.

Check with a qualified electrician or service personnel if you do not understand these grounding requirements, or if you are in doubt about whether the tool is properly grounded. If you ever notice that a cord or plug is damaged or worn, disconnect it from power, and immediately replace it with a new one.

Full Load Amperage

Amp draw at 220V (prewired)..... 22.4 Amps

Power Supply Circuit Requirements

The power source circuit for your machine must be grounded and rated for the amperage given below. Never replace a circuit breaker on an existing circuit with one of higher amperage without consulting a qualified electrician to ensure compliance with wiring codes. **If you are unsure about the wiring codes in your area or you plan to connect your machine to a shared circuit, consult a qualified electrician.**

Circuit Size (220V)..... 40 Amp min.

LAGUNA

⚠ DANGER

IN ALL CASES, MAKE CERTAIN THE RECEPTACLE IN QUESTION IS PROPERLY GROUNDED. IF YOU ARE NOT SURE, HAVE A QUALIFIED ELECTRICIAN CHECK THE RECEPTACLE.

220 VOLT Single-Phase Operation

The motor supplied with your machine is a 220 volt motor. It is shipped ready-to-run for 220 volt operation.

FUNCTION

Control Panel

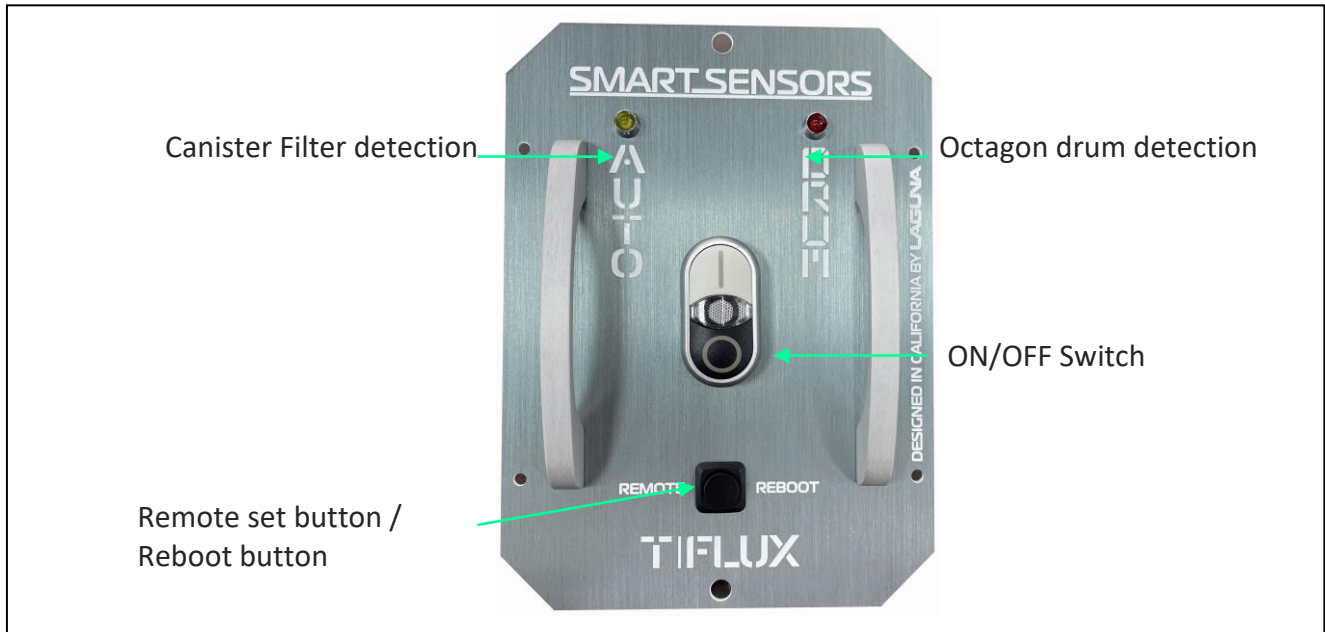

Remote Control

Requires a 12V, type 27A alkaline battery.



*Used to match up a new hand held control with the remote switch



This machine is programmed to clean the canister filter during operation every 10 minutes. It will clean for 10 seconds clockwise and another 10 seconds counterclockwise. When you switch OFF the unit, after 30 seconds when the fan comes to a complete stop, the canister filters will clean for 10 seconds clockwise and another 10 seconds counterclockwise.

SPECIFICATIONS

Motor Specs:	5 HP
Electrical Specs:	220V / 60Hz / 1PH / 3450 RPM
Running AMP	(with 10" inlet) 22.4A at 220V
Air Volume:	2162 CFM (cubic feet per minute)
Max. static pressure	14 inches of water
Fan size	16"
Inlet:	Ø10"
Switch	High frequency remote control switch
Collection capacity	54 gallon octagon drum
Packing Size: (L x W x H)	74" x 39" x 78" (188 x 99 x 198 cm)
Machine weight	717 lbs. (325 kgs)
Shipping weight	948 lbs. (430 kgs)

<u>Filter Media</u>	filtering area: 15 m2 (162 ft2)
Cartridge Filter	1 Micron Ø23.62" x 47.24" (Ø60 x 120cm) x 1pc

LAGUNA

UNPACKING

Your 5HP Stationary Dust Cyclone comes packed in a single wooden crate. Before attempting to assemble this machine, follow these directions for unpacking:

1. Carefully remove the wooden crate walls...
2. Carefully take out the machine components from the box and set aside.
3. Using the diagram below, ensure that all parts are present and in good condition.

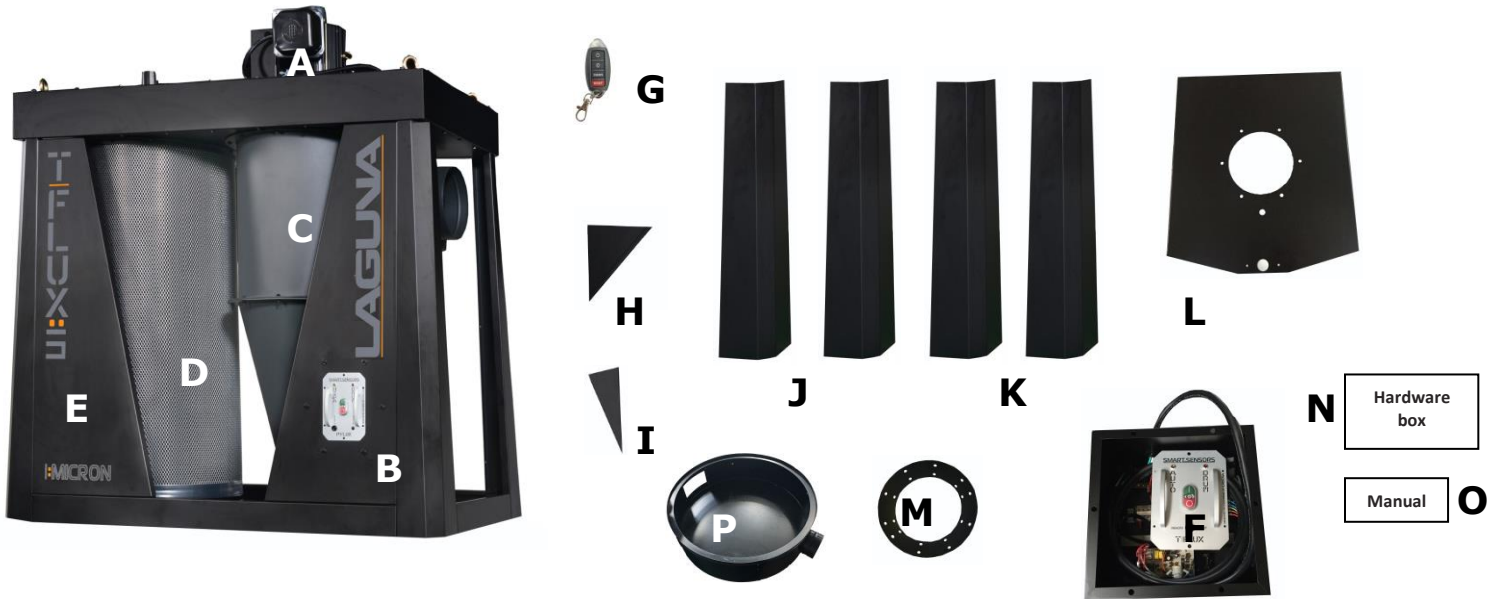

DESCRIPTION (QUANTITY)

- | | |
|------------------------------------|-----------------------------------|
| A. Motor | I. Triangular cover plates – side |
| B. Support panel | J. Lower upright support – right |
| C. Cyclone | K. Lower upright support – left |
| D. Canister filter | L. Drum lid |
| E. Support panel | M. Vacuum suction plate |
| F. Control panel and box | N. Hardware box |
| G. Hand held remote controller | O. Operating and Parts Manual |
| H. Triangular cover plates – front | P. Canister end cap |

Report any missing or damaged parts to your dealer or distributor. Prior to tool assembly and use, read this manual thoroughly to familiarize yourself with proper assembly, maintenance and safety procedures.

LAGUNA

ASSEMBLY

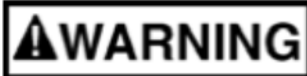

This step requires two adults. This 5HP Stationary Dust Cyclone is heavy, be careful when lifting and handling it! Failure to comply may cause serious injury and/or damage to the machine and/or property!

Tools Required

10mm wrench / 12mm wrench / 14mm wrench

Phillips screwdriver

4mm hex wrench / 5mm hex wrench

To assemble your dust cyclone, follow these steps:

For your own safety, do not connect the machine to the power source until the machine is completely assembled. Please also make sure that you read and understand the entire instruction manual.

ASSEMBLY TIME ESTIMATE 1 - 2 hours

Step One: Use a forklift to lift the unit up by using a chain and hooking on end of the chain to the right top eye bolt; and the other side to the left top eye bolt. Slowly lift the unit up to a height where you will be able to assemble the lower upright supports.

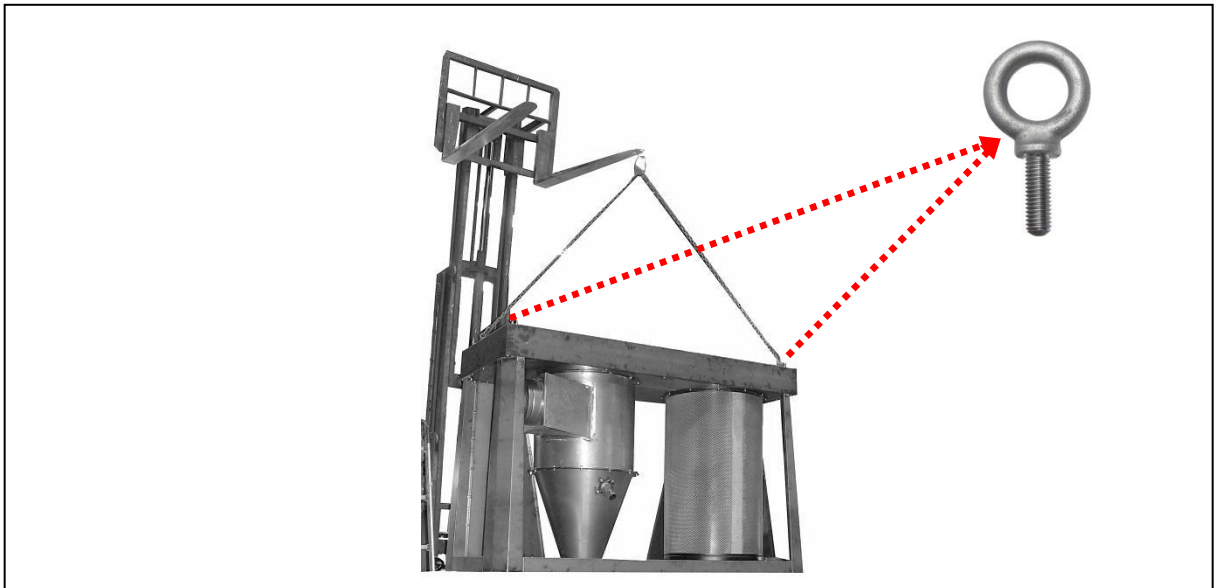

LAGUNA

Step Two: Secure the (2) lower upright supports; one on the front right side of the machine when facing the control panel and the other on the back left side (diagonally across). These two lower upright supports have a one dot marking on the side rim, as shown below. Use (4) 3/8" *1" hex bolts and (8) 3/8" *OD23*2t flat washers and (8) 3/8" lock nuts for the two side bolt holes.

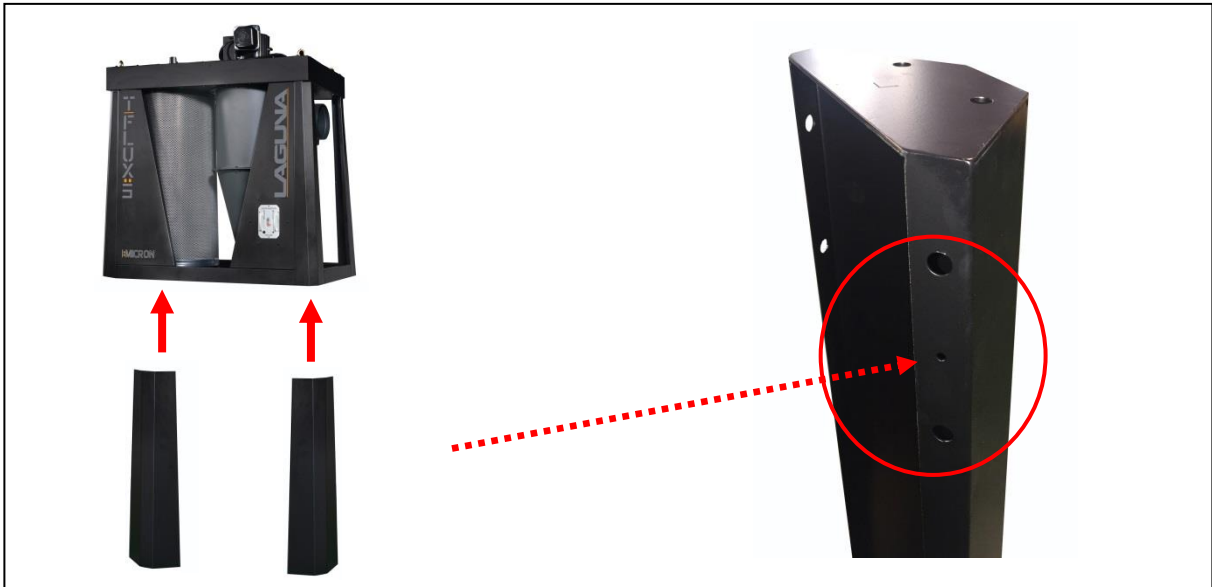

Step Three: Secure the (2) lower upright supports; one on the front left side of the machine when facing the control panel and the other on the back right side (diagonally across). These two lower upright supports have a two dot marking on the side rim, as shown below. Use (4) 3/8" *1" hex bolts and (8) 3/8" *OD23*2t flat washers and (8) 3/8" lock nuts for the two side bolt holes and use (1) M16*50mm hex bolt for the center bolt.

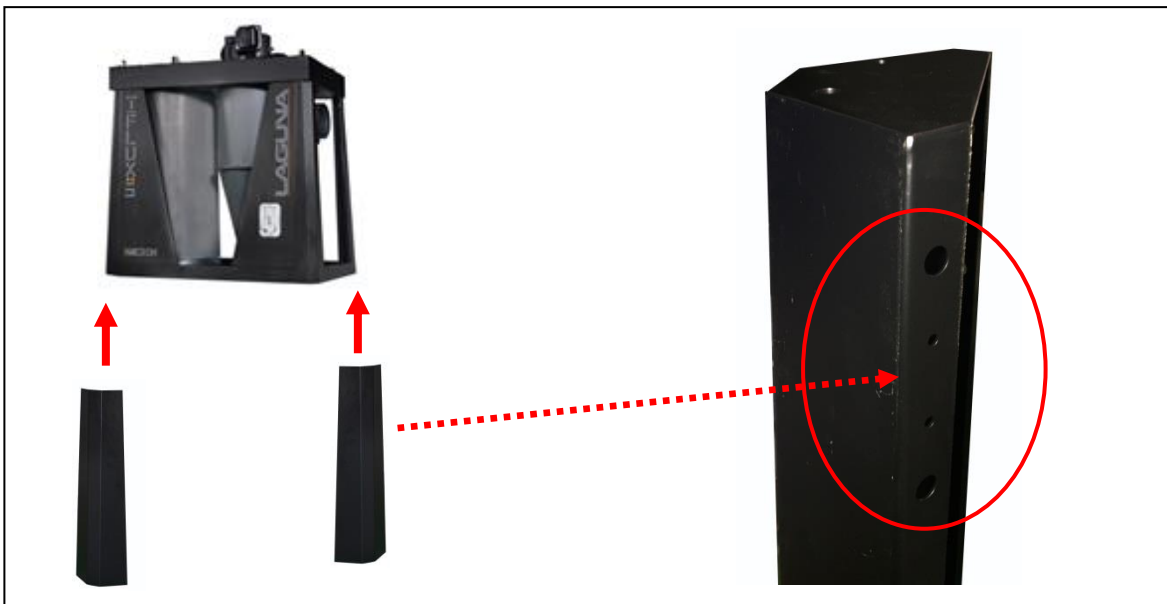

LAGUNA

Step Four: Secure the (2) triangular cover plates to the front of the unit; facing the control side. Use (8) 5/16" *1" hex bolts, (16) 5/16" *OD18*2t flat washers and (8) lock nuts.



Step Five: Secure the (2) triangular cover plates to the back of the unit. Use (8) 5/16" *1" hex bolts, (16) 5/16" *OD18*2t flat washers and (8) lock nuts.

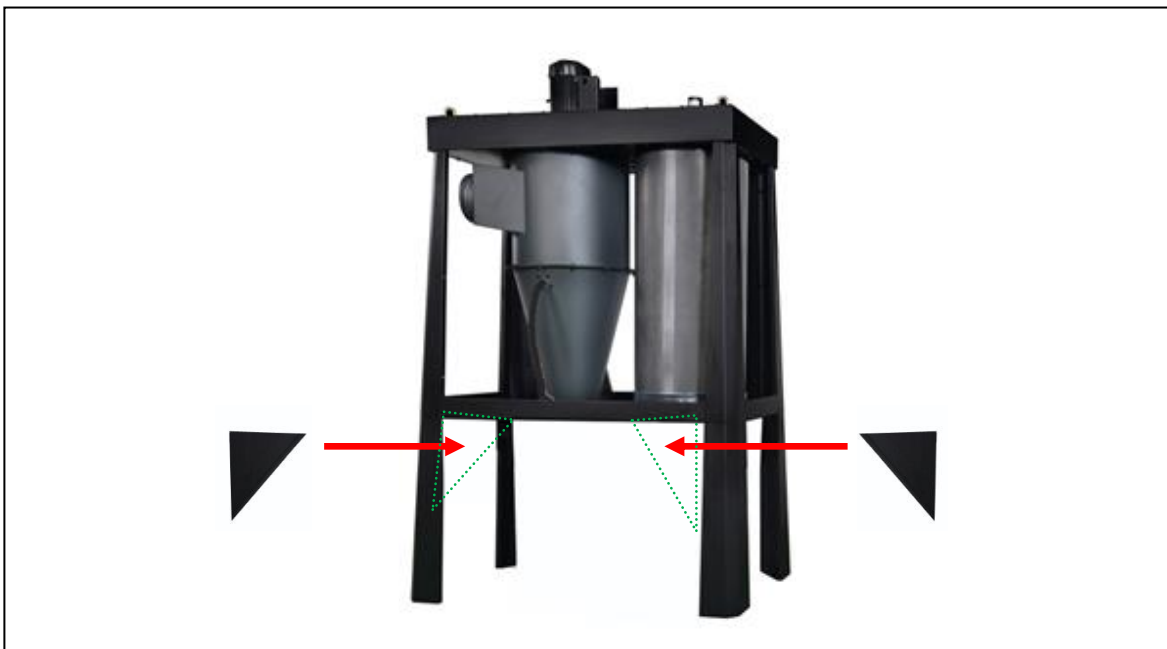

LAGUNA

Step Six: Secure the (2) triangular cover plates to the right side of the unit; facing the control side. Use (8) 5/16" *1" hex bolts, (16) 5/16" *OD18*2t flat washers and (8) lock nuts.



Step Seven: Secure the (2) triangular cover plates to the left side of the unit; facing the control side. Use (8) 5/16" *1" hex bolts, (16) 5/16" *OD18*2t flat washers and (8) lock nuts.



LAGUNA

Step Eight: Take the drum lid vacuum suction tube and attach to the drum lid using (2) 1/4"*3/4" hex bolts and (2) 1/4"*OD19*2t flat washers.

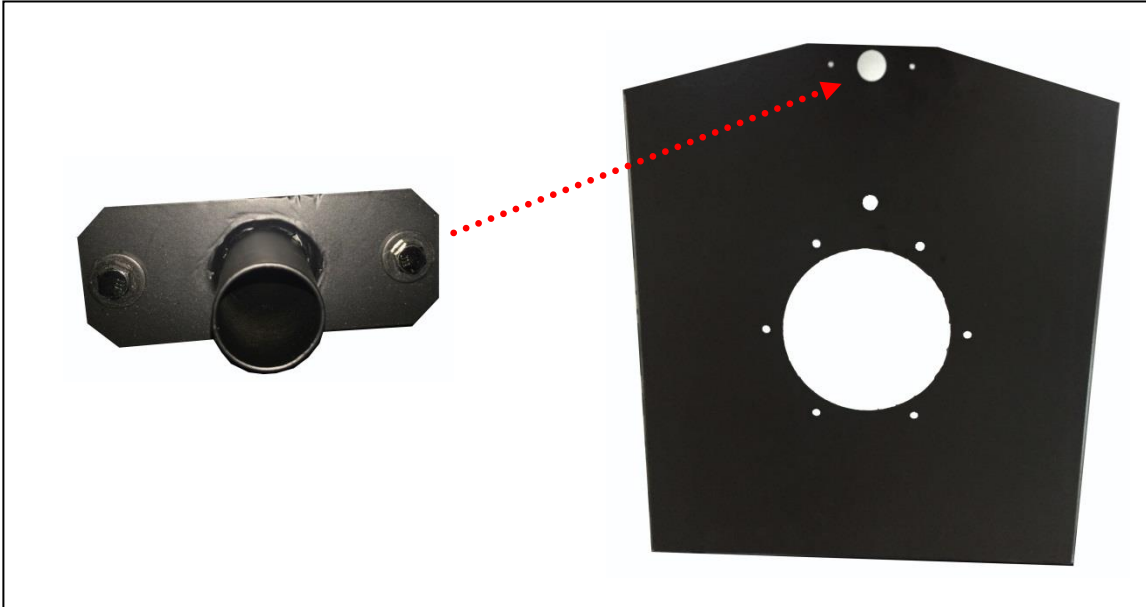

Step Nine: Attach the one end of the black flex hose to the vacuum tube on the cyclone funnel and the other end to the top end of the vacuum suction tube connector. Secure and fix the flex hose with the hose clamps.

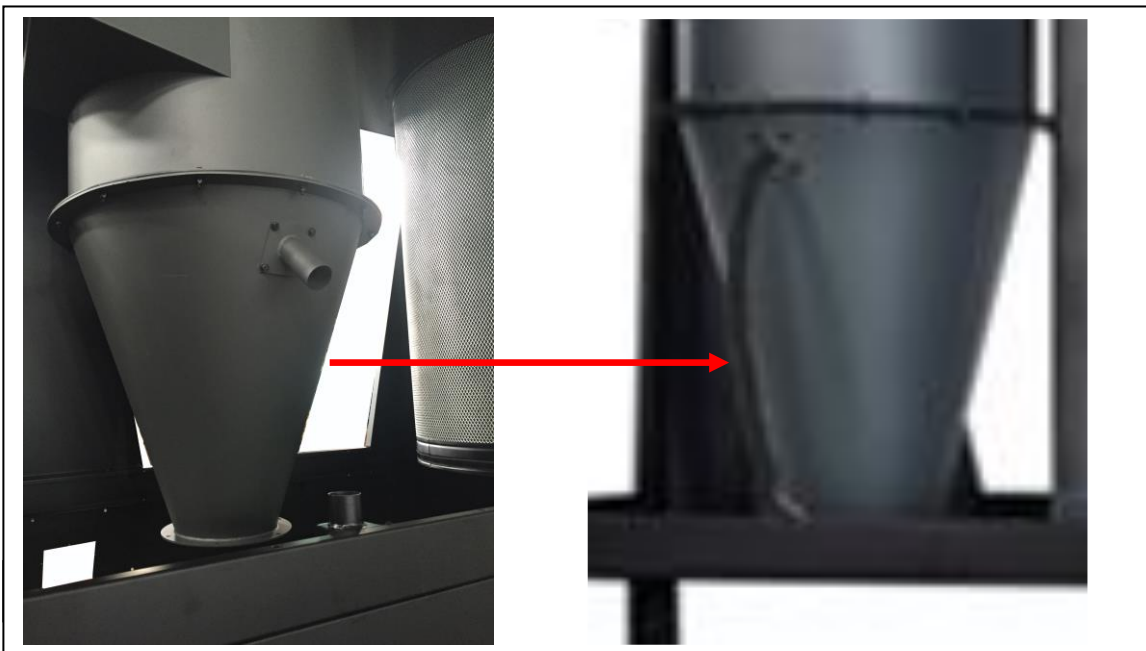

LAGUNA

NOTE: If you do not want to use a plastic bag inside the octagon collection drum, you need to block off the negative pressure. There is a little pack containing the items needed to do this. You will also need take the (4) 1/4"*1/2" carriage bolts, (4) 1/4"*OD19*2t flat washers and (4) 1/4" hex nuts that were securing the vacuum suction pipe to assemble the cover plates. The vacuum suction pipe on the drum will be removed for this. It will not have a purpose if you block off the negative pressure.

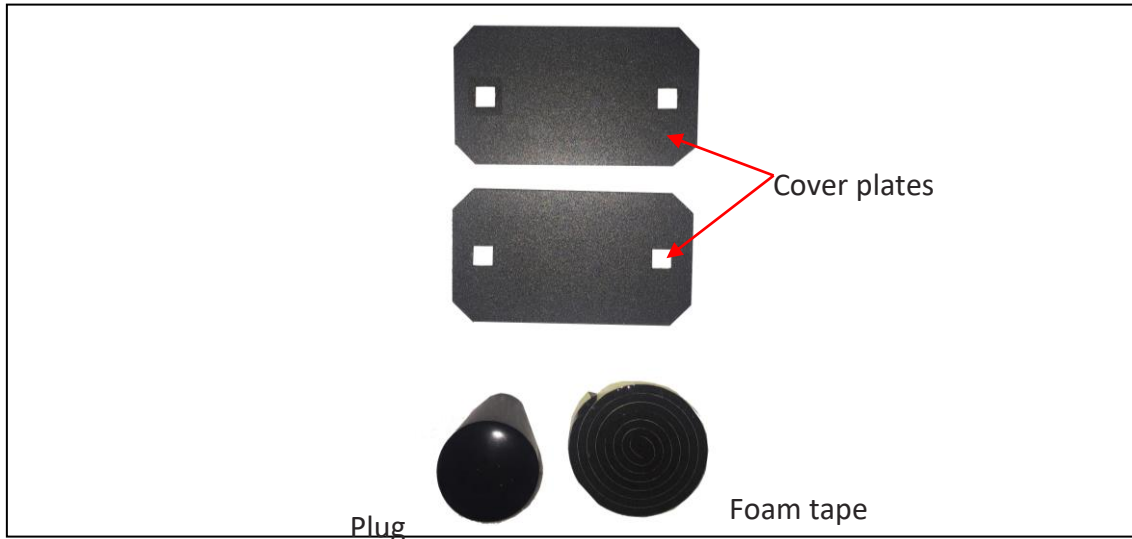

- 1.1. Remove the vacuum suction pipe from the drum by loosening the (4) 1/4"*1/2" carriage bolts, (4) 1/4"*OD19*2t flat washers and (4) 1/4" hex nuts mentioned in the previous step. There will be 2 sets from the top and 2 sets from the bottom of the vacuum suction pipe.



LAGUNA

- 1.2. Take the one of the cover plates, (2) 1/4"*1/2" carriage bolts, (2) 1/4"*OD19*2t flat washers and (2) 1/4" hex nuts and secure the cover plate to the opening on the top of the drum. For the bottom holes do the same, but first use foam tape to cover the square opening before bolting on the cover plate.

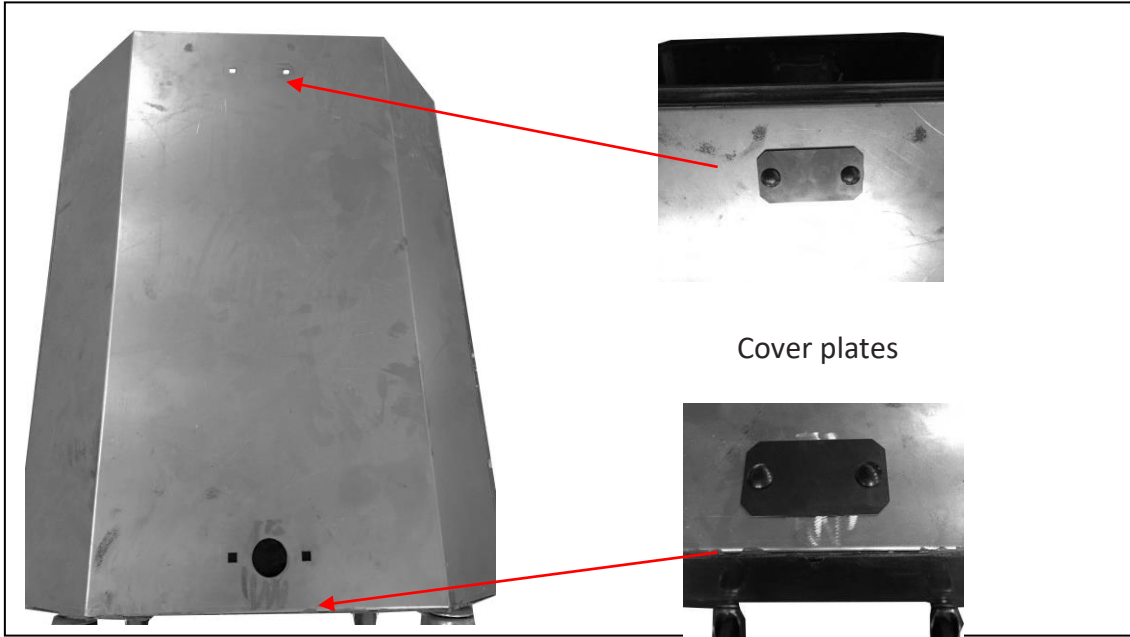

- 1.3. Remove the flex hose and clamps from the cyclone cone in step forty one. Locate the plug provided inside the hardware box and attach over the vacuum suction tube as shown in the picture on the right below.

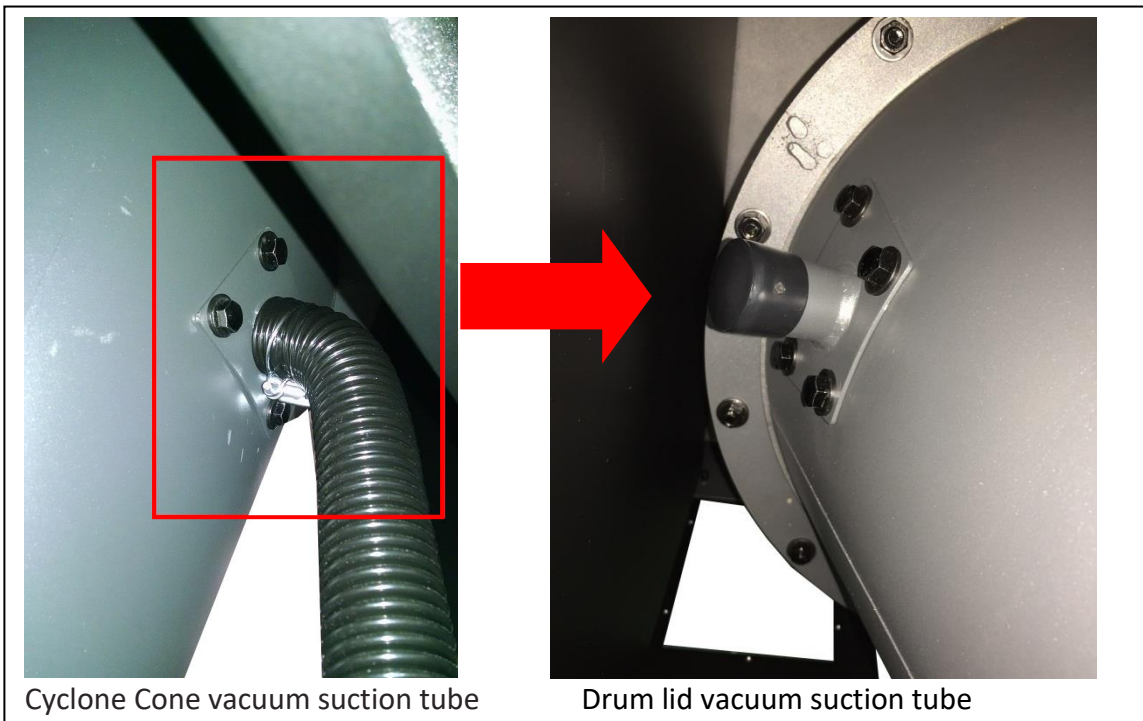

LAGUNA

Step Ten: Take the drum lid and apply the 3*6mm foam tape provided to the center opening. Go along the inner ring and avoid covering the bolt holes. After you have finished with applying the foam tape, secure the drum lid to the cyclone funnel flange. Use (6) 5/16"*1" hex bolts, (12) 5/16"*OD18*2t flat washers and (6) 5/16" lock nuts.

Make sure that the end with the vacuum suction tube is facing the back, away from the control panel side.

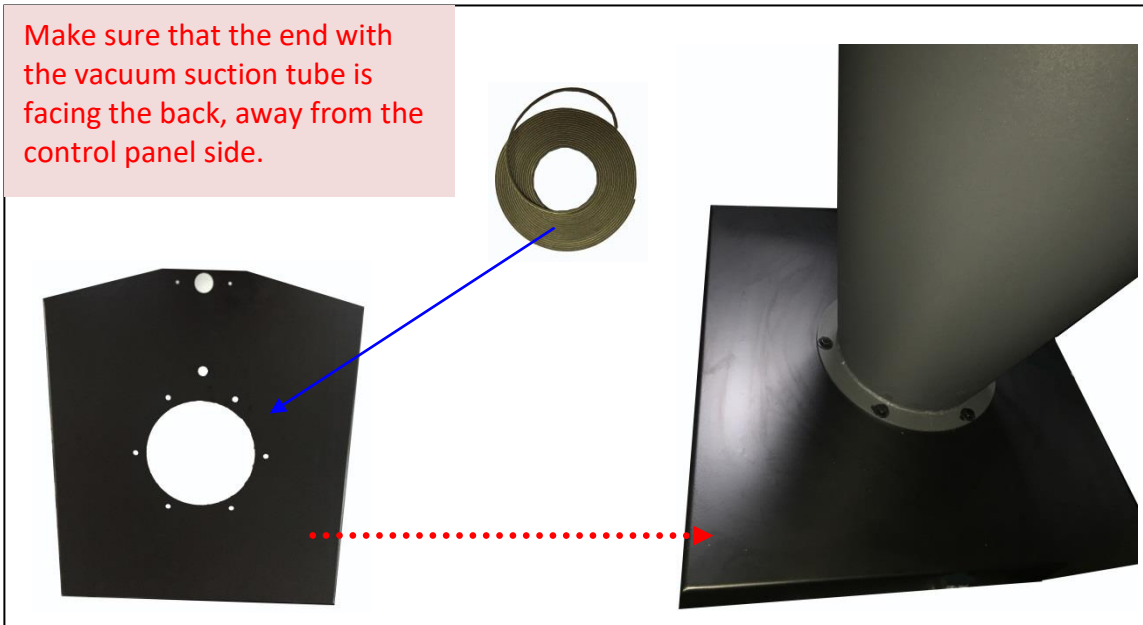

Step Eleven: Take the crossbar and attach to the drum lid and tighten using the two bolts removed in the previous step. It does not matter which position you attach the crossbar. As long as it does not obstruct the sensor on the drum lid.

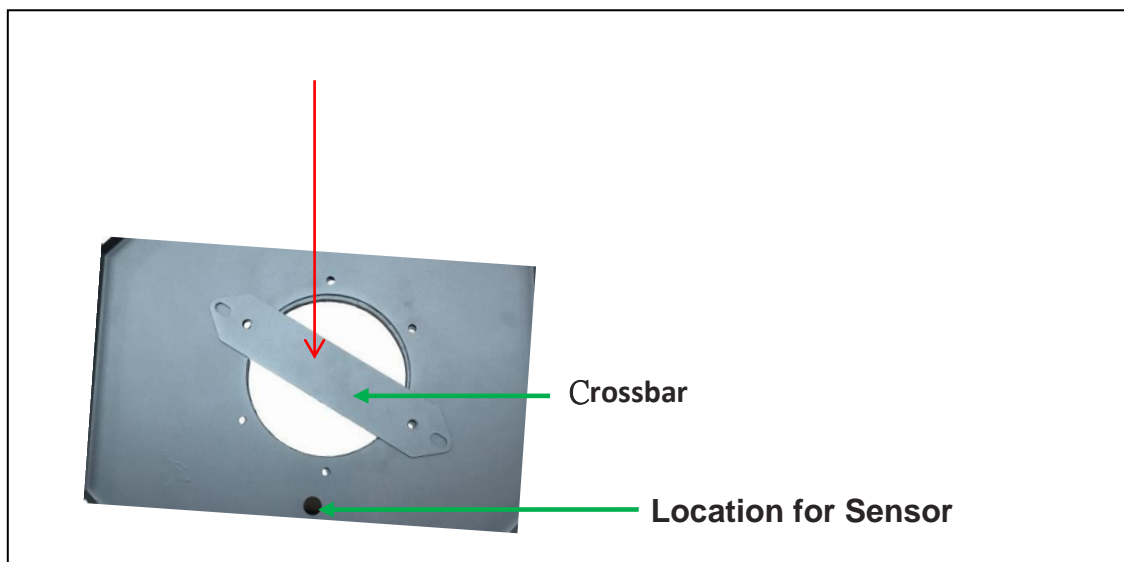

LAGUNA

Step Twelve: Take the proximity sensor and cord leading from the control box and assemble to the top of the drum lid.



Step Thirteen: First remove one of the black screws off the sensor then thread the sensor through the hole on the drum lid. Take the black screw and tighten the other end of the sensor that is on the inner side of the lid.



LAGUNA

Step Fourteen: Make sure that the proximity sensor is not thread in too deeply into the drum lid. As this will create interference when the drum is inserted and may hit the proximity sensor creating damage.

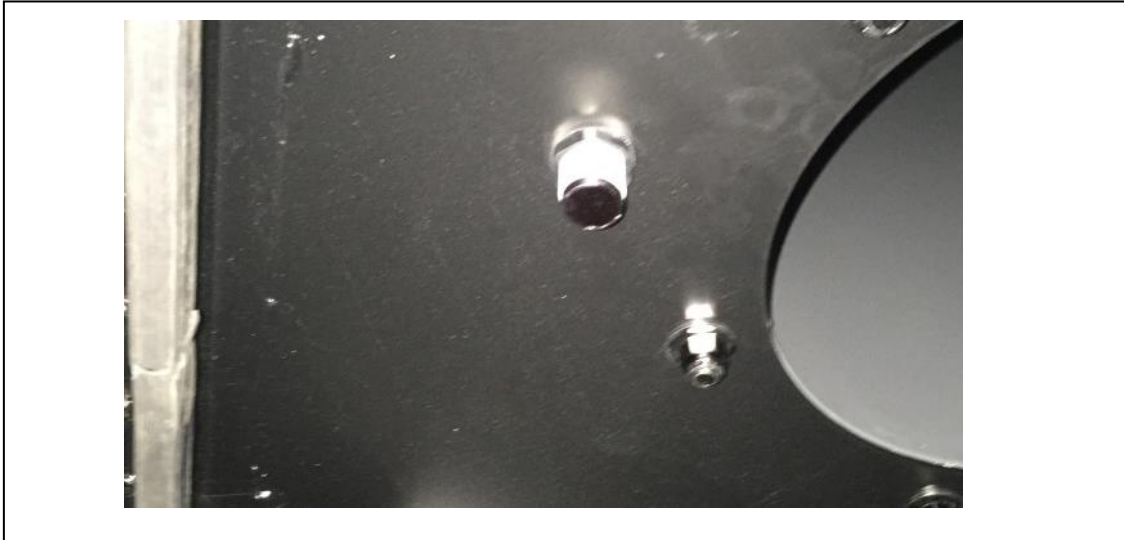

Step Fifteen: To adjust the distance of the sensor to detect the dust waste level use the white plastic pin that was provided in the hardware box.

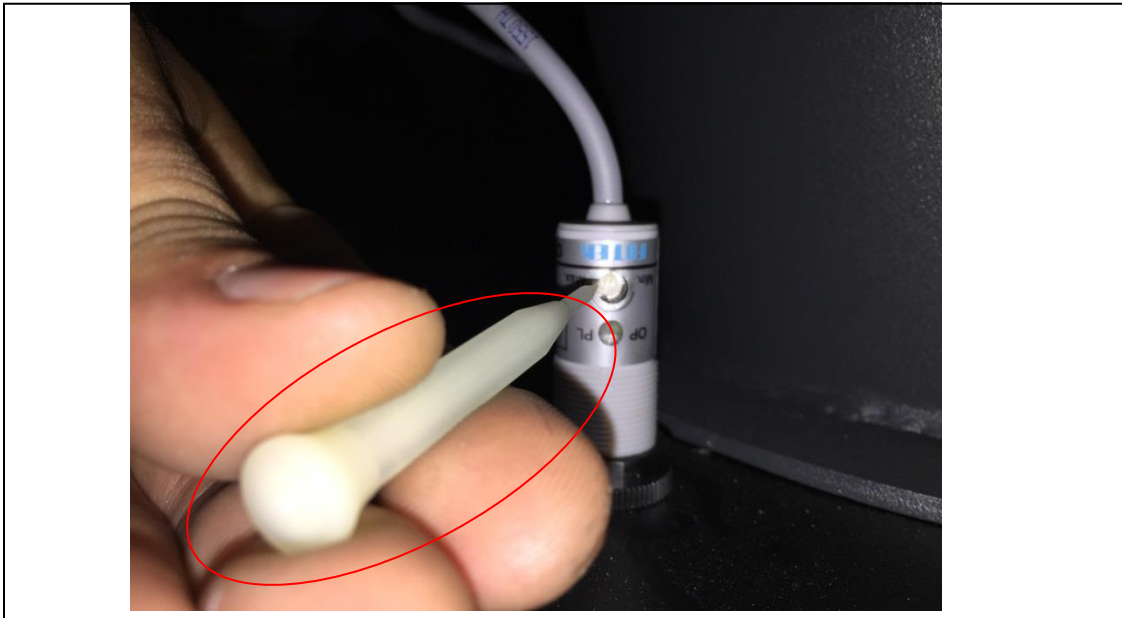

LAGUNA

Step Sixteen: Using the white plastic pin, insert the sharp point into the top end of the proximity sensor that is on top of the drum lid. You will find a small hole to on top where you can turn clockwise or counter clockwise.

※Clockwise: Lower dust waste level in drum (Less full drum)

※Counterclockwise: Higher dust waste level in drum (Fuller drum)



Step Seventeen: Secure the latch base plate to the front side of the drum lid using (2) 3/16" *3/8" round head bolts.



LAGUNA

Step Eighteen: Secure the casters to the drum base panel using (8) 3/8" *OD23*2T flat washers and (4) 3/8" nuts.



Step Nineteen: Assemble the front and back panel to the drum base using (10) 5/16" *5/8" Philip hd bolts, (20) 5/16" *OD18*2t flat washers and (10) 5/16" nuts.



LAGUNA

Step Twenty: Assemble the side panels to the drum using (6) 5/16" *5/8" Philip hd bolts, (12) 5/16" *OD18*2t flat washers and (6) 5/16" nuts to secure the base. And then use (16) 5/16" *5/8" Philip hd bolts, (16) 5/16" *OD18*2t flat washers and (16) 5/16" nuts to secure the panels to each other.



Step Twenty One: Assemble the top rim to the panels using (11) 5/16" *5/8" Philip hd bolts, (11) 5/16" *OD18*2t flat washers and (11) 5/16" nuts.



LAGUNA

Step Twenty Two: Assemble the latch to the drum using (4) 3/16" *3/8" round head thread bolts.

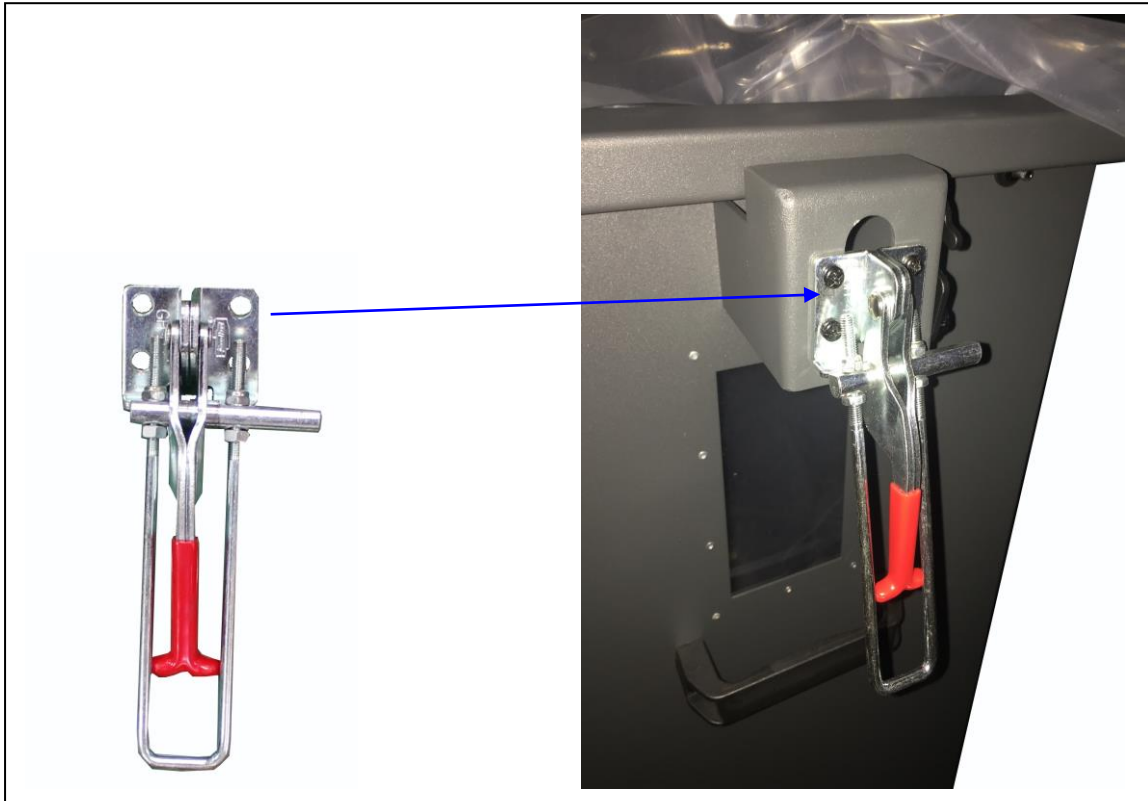

Step Twenty Three: Assemble the drum vacuum suction tube to the back panel using (4) 5/16" *3/4" hex bolts and (8) 5/16" *OD18*2T flat washers.



LAGUNA

Step Twenty Four: Attach the Ø1-1/4" x0.8M black flex hose to the drum vacuum suction tube and use the Ø1-1/4" hose clamp to tighten and secure the black flex hose in place.



Step Twenty Five: Attach the other end of the Ø1-1/4" x0.8M black flex hose to the drum lid vacuum suction tube and use the Ø1-1/4" hose clamp to tighten and secure the black flex hose in place.

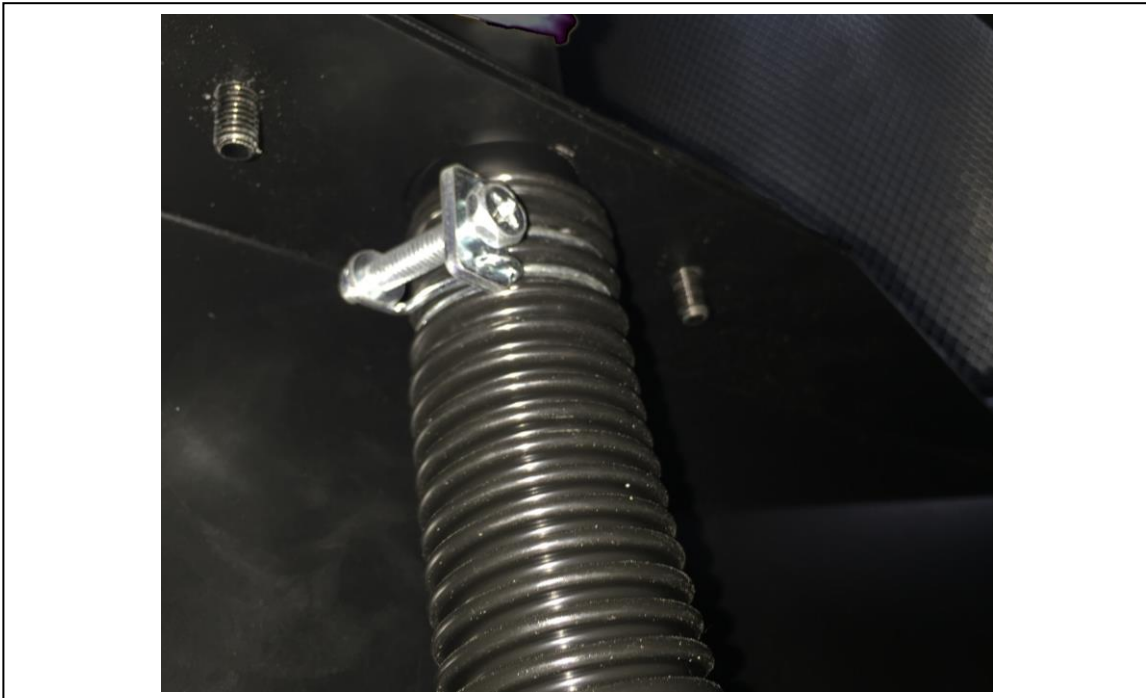

LAGUNA

Step Twenty Six: Place the vacuum suction ring inside before inserting the plastic bag in the Octagon drum.

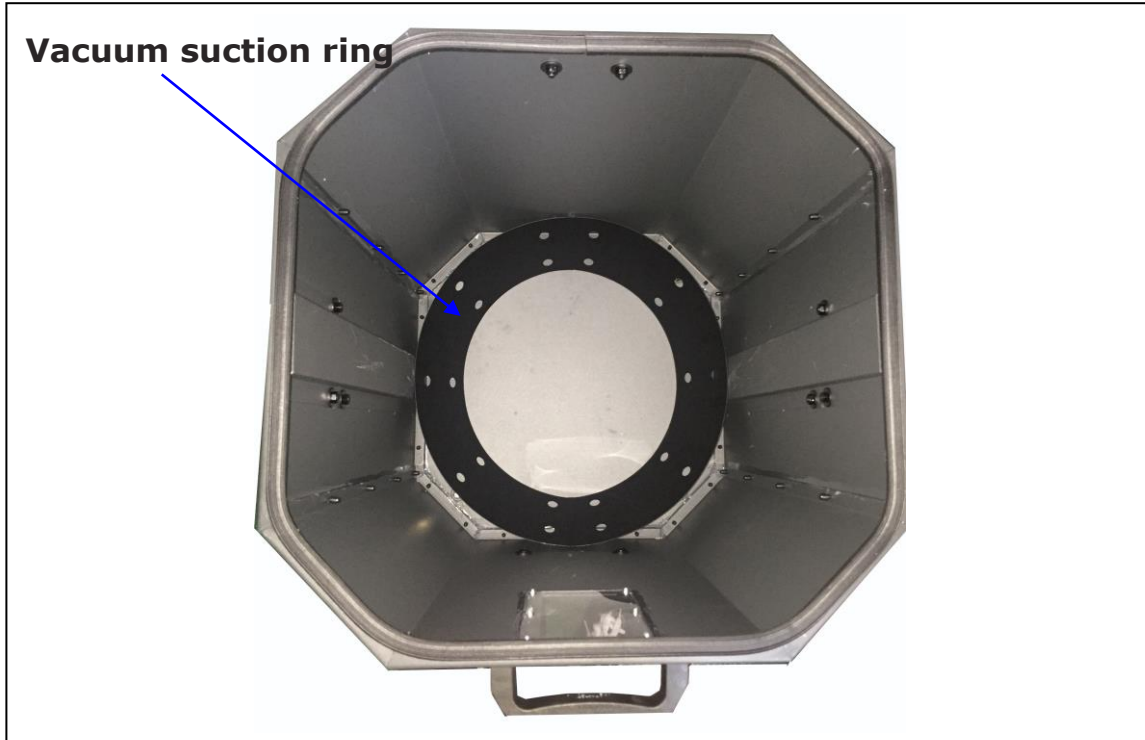

Step Twenty Seven: Once completing the assembly, apply silicone to the inside of the drum including the base to seal and prevent air leakages.

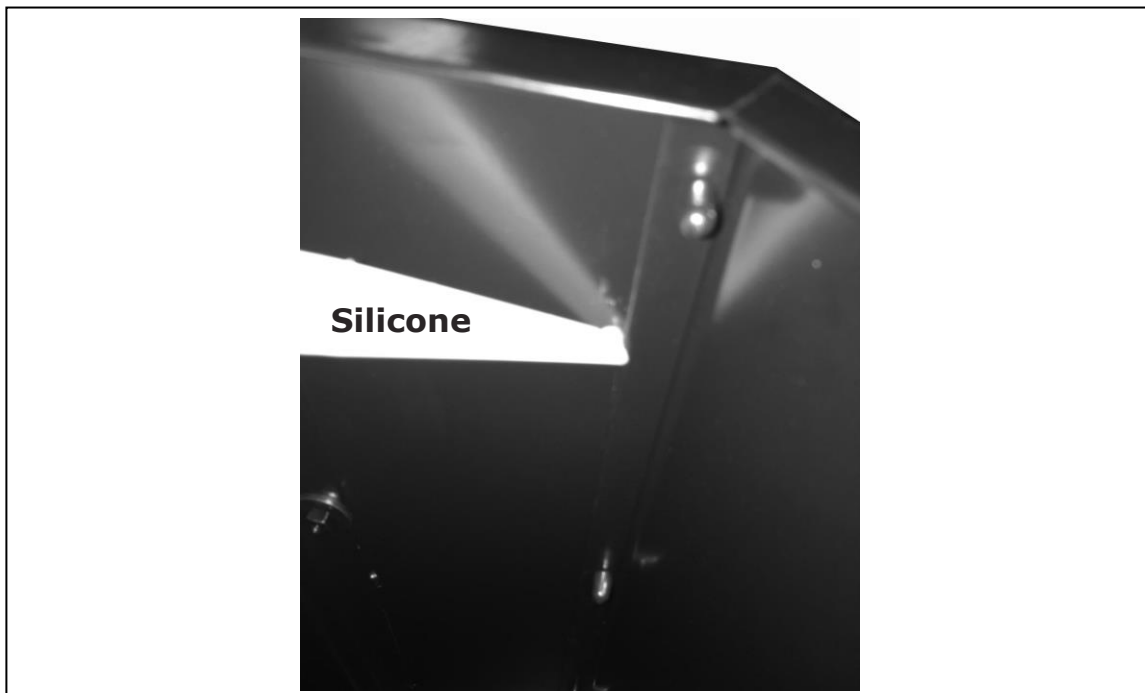

LAGUNA

Step Twenty Eight: To connect the power cord from your power supply to the control box, you must first detach the control panel from the side panel. Loosen the (6) 3/16" *3/8" round head bolts.



Step Twenty Eight: Insert the control panel through the hole in the side panel to place in the control box before detaching the control box.

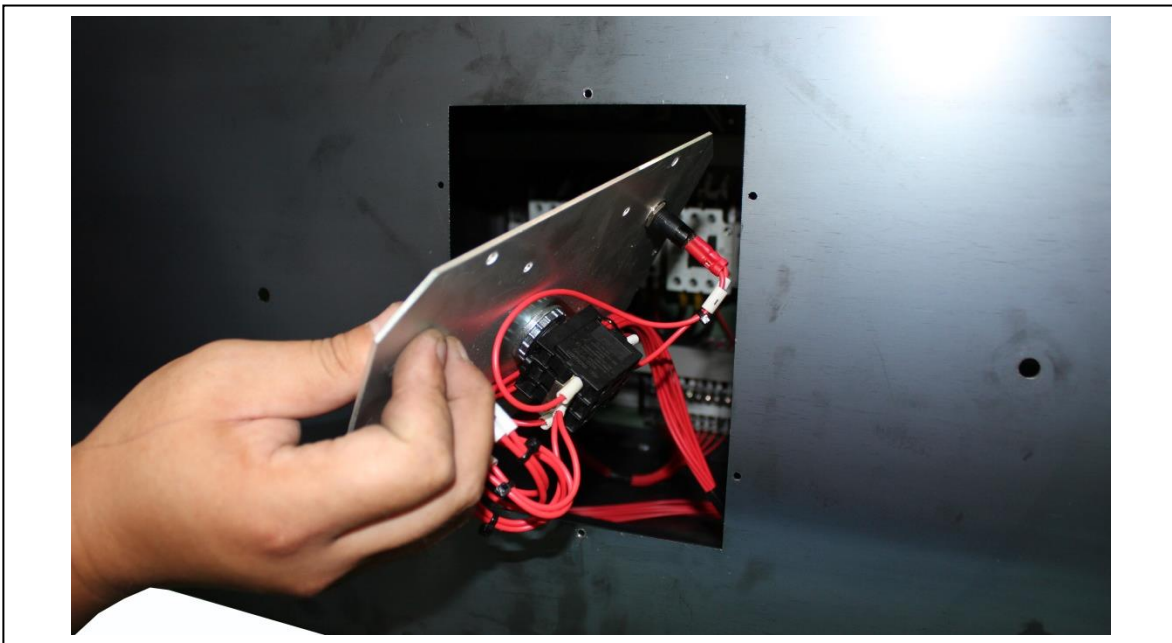

LAGUNA

Step Twenty Nine: Remove the control box from the side panel by loosening (6) 1/4" *3/4" hex bolts and (6) 1/4" *OD19*2t flat washers.



Step Thirty: Punch out a hole in the control panel next to where the motor cord is located. Refer to circled area in the location shown below



LAGUNA

Step Thirty One: Thread the power cord through the hole in the control box and connect to L1 and L2 terminal.

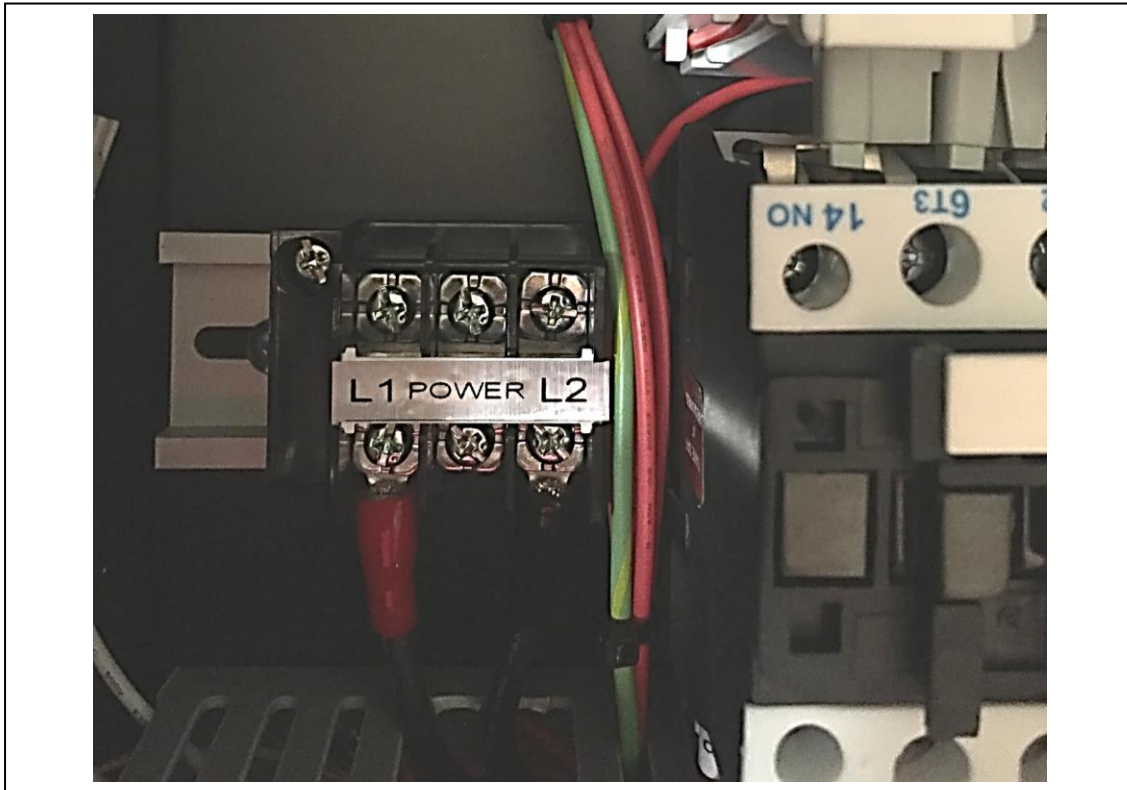

Step Thirty Two: Reassemble the control box and control panel back in place following steps 19 to 21 in reverse.

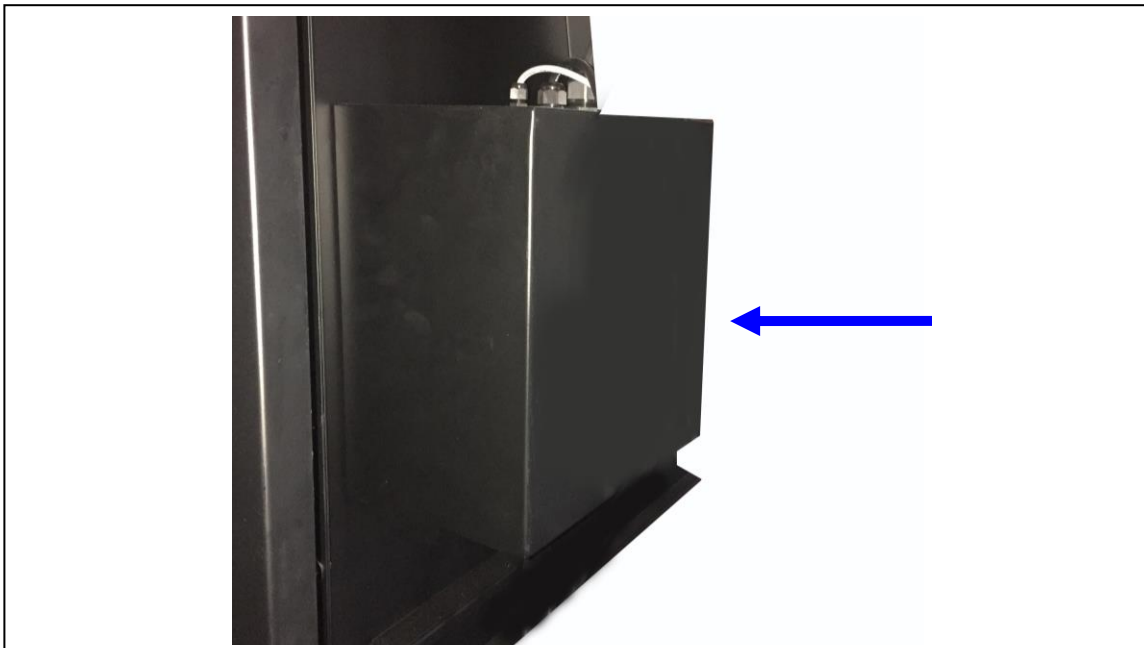

LAGUNA

Step Thirty Three: Apply foam tape to the inner rim of the canister end cap before attaching to the canister filter to complete the setup of your cyclone.

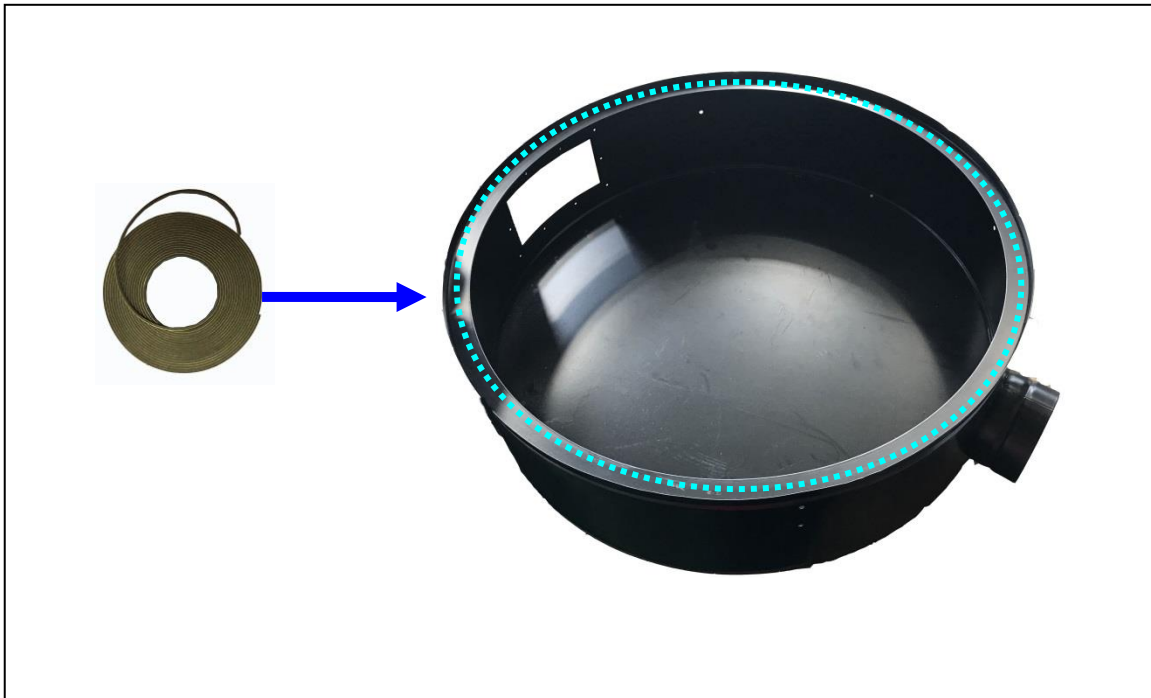

CLEANING THE FILTER

To ensure proper operation of this Dust Cyclone, the canister filter must have adequate air flow. This means the filter must be regularly maintained by carefully blowing the filter clean using compressed air and an air gun to release built-up particulates trapped between the filter pleats.

For heavy duty users, it is recommended to use compressed air on a regular basis to maintain maximum filtration efficiency and longer life span of the filter.

Auto cleaning motor

The machine is equipped with an auto cleaning system that will clean the canister filter in an hourly interval for 10 seconds one way and another 10 seconds the other way. The cleaning will stop when you shut the machine off. While the canister is cleaning the LED light will illuminate showing that it is in the process of cleaning.

LAGUNA

Using Compressed Air



DISCONNECT MACHINE FROM POWER!

For heavy duty users, it is recommended to use compressed air on a weekly basis to maintain maximum filtration efficiency and longer life span of the filter.

REMOVING THE CANISTER FILTER

1. Open the maintenance door on the canister cover plate sitting on top of the dust chute where the gear motor is located.

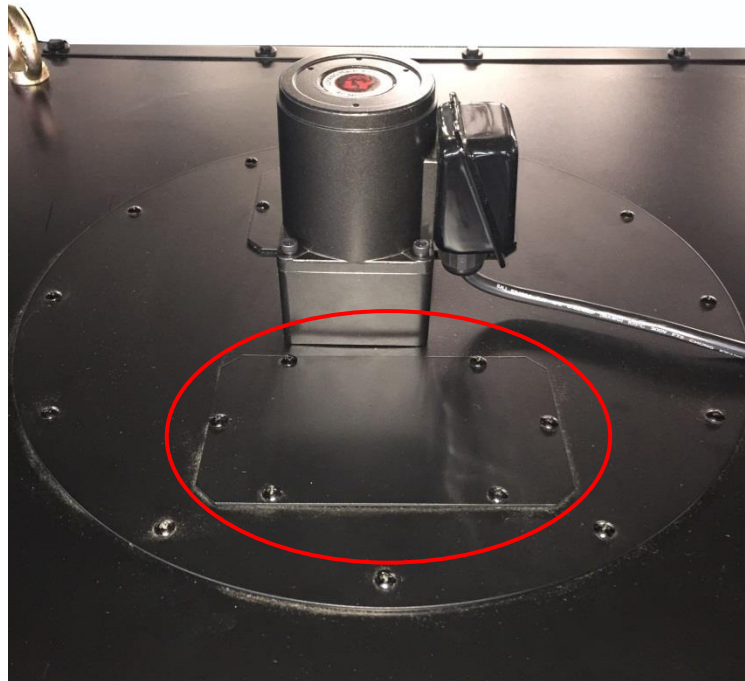

2. Loosen the bolt off of the rotation shaft as shown below. Set the shaft aside for later use. Keep the bolt for use when reassembling the rotation shaft.

LAGUNA

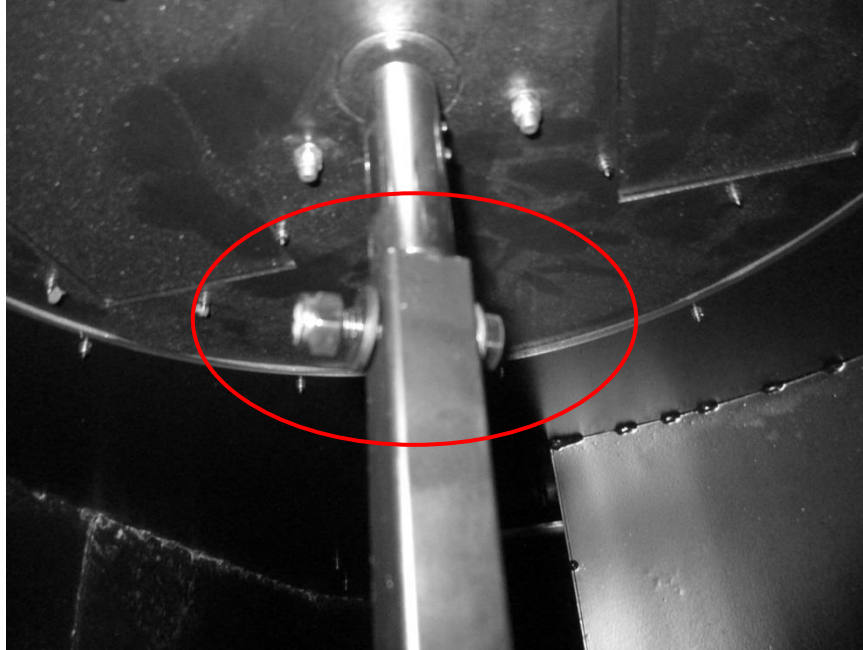

3. With the help of another person, loosen the 12 bolts holding the canister filter to the dust chute. Carefully remove the canister filter off from the dust chute.



LAGUNA

4. With the canister filter removed use a compressed air gun to thoroughly clean between the pleats, both inside and outside.

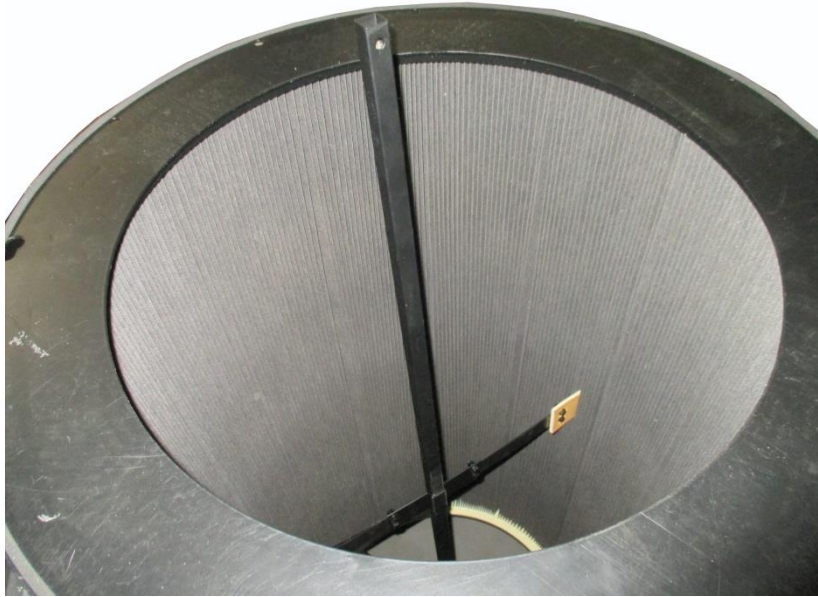

RE-ASSEMBLING THE CANISTER FILTER AFTER CLEANING

1. With the aid of another person, carefully re-insert the canister filter repeating steps above in reverse.

EMPTYING OR REPLACING THE FILTER BAG

Periodically check the filter bag, if it is more than one third full, it is recommended that you empty it.

NOTE: If the filter bag gets too full, the weight may force it to pull away from the band clamp, exposing the user to potentially harmful particulates.

1. Release the spring-loaded band clamp at the bottom of the filter and remove the filter bag.
2. Empty or replace the filter bag and re-attach using the spring-loaded band clamp.

EMPTYING THE DRUM

Periodically inspect the contents of the drum and empty as needed. To inspect the contents of the drum:

1. Lift the red hand on the latch on the drum lid to lower the drum.



2. Roll it away from the machine, inspect and empty as needed.

ROUTINE INSPECTION

It is a good idea to routinely inspect any quality woodworking tool in order to keep it in optimum condition. This includes inspecting all hardware for tightness, ensuring the filter is clean, and cleaning debris and grime from any surfaces and moving parts.



TROUBLESHOOTING GUIDE

Symptom	Possible Cause	Possible Solution
Machine does not start or a breaker trips.	Power supply switched OFF or is faulty.	Ensure power supply is ON and has the correct voltage.
	Wall fuse/circuit breaker is blown/tripped.	Ensure adequate circuit size; install inlet restrictor, replace weak breaker.
	Faulty remote control.	Replace batteries; ensure unobstructed line-of-sight and signal range.
	Remote receiver is faulty.	Inspect receiver circuit board; replace if faulty.
	Incorrectly wired motor connection.	Rewire or call certified service technician or electrician.
	On-board circuit breaker is tripped.	Allow motor to cool, improve ventilation, press reset button.
	Wiring is open/has high resistance.	Check for broken wires or poor connections, repair as necessary.
	Faulty power switch.	Replace switch.
Excessive vibration or noise during operation.	Motor is at fault.	Test/repair/replace.
	Loose component.	Inspect and tighten all bolts/nuts.
	Loose or broken motor mount.	Tighten or replace as needed.
	Motor fan hitting fan cover.	Check fan and cover; replace as needed.
	Bad motor bearings.	Rotate shaft manually, check for grinding or loose shaft, replace bearings if needed.

LAGUNA

<p>Loud, repetitive noise, or excessive vibration coming from cyclone</p>	<p>Machine is on uneven surface.</p> <p>Damaged/Unbalanced impeller.</p> <p>Loose connections.</p> <p>Impeller is loose.</p> <p>Motor fan hitting fan cover.</p>	<p>Stabilize on a flat surface.</p> <p>Inspect impeller for dents, bends, loose fins. Replace if needed.</p> <p>Check and re-tighten all fasteners.</p> <p>Replace the motor and impeller.</p> <p>Check fan and cover; replace as needed.</p>
<p>Dust cyclone does not adequately collect dust or chips; poor performance.</p>	<p>Canister end cap is full.</p> <p>Filter is dirty.</p> <p>Restricted duct line.</p> <p>Suction route is too long or has too many sharp bends.</p> <p>Wet lumber is clogging ducts.</p> <p>Leaks in the duct work or too many open ports.</p> <p>Inadequate velocity in the main suction line.</p> <p>Wrong size ducting/ports used.</p>	<p>Empty canister end cap.</p> <p>Clean filter.</p> <p>Clean inlet splitter.</p> <p>Move machine closer to the point of suction, and rerun ducts to eliminate sharp bends.</p> <p>Use lumber with less than 20% moisture content.</p> <p>Repair all duct leaks and close any ports not being used.</p> <p>Increase velocity by opening 1 or 2 more blast gates to different branch lines.</p> <p>Re-size and re-install ducts and fittings.</p>
<p>Sawdust being blown into the air from the dust cyclone</p>	<p>Band clamp or end cap is not secure.</p> <p>Loose or damaged seals.</p>	<p>Re-install ensuring a tight fit.</p> <p>Replace seals and gaskets.</p>

Exploded View

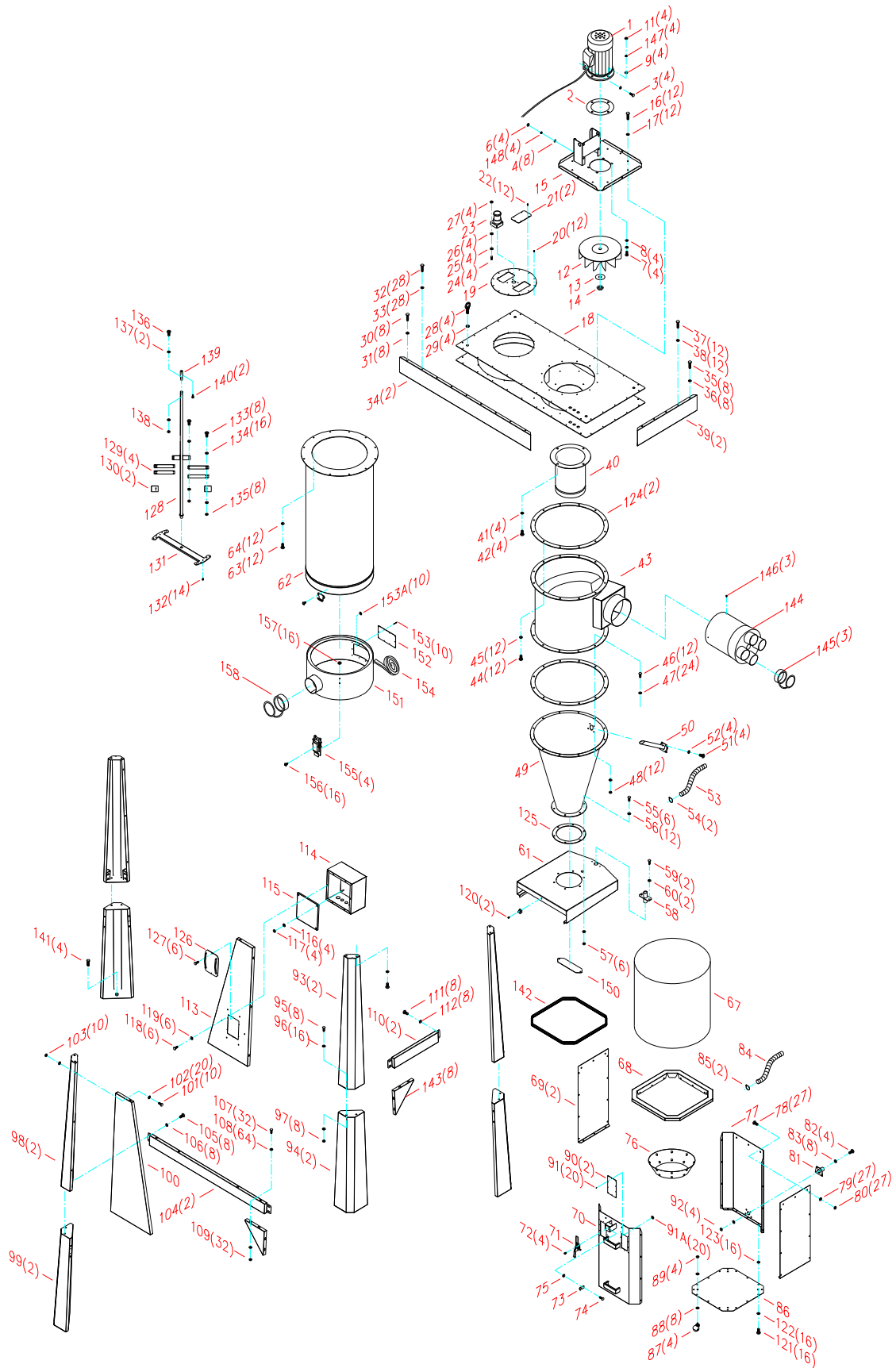

LAGUNA

Parts List				
Ref#	Part #	Part Name	Description	QTY
1	PDCTF52201-1	MOTOR	5HP/220V/60Hz/1Ph	1
2	PDCTF52201-2	MOTOR GASKET		1
3	PDCTF52201-3	HEX BOLT	3/8"*1-1/2"	4
4	PDCTF52201-4	FLAT WASHER	3/8"*OD23*2t	8
6	PDCTF52201-6	HEX NUT	3/8"	4
7	PDCTF52201-7	HEX BOLT	1/2"*1-1/2"	4
8	PDCTF52201-8	FLAT WASHER	1/2"*OD34*3t	4
9	PDCTF52201-9	FLAT WASHER	1/2"*OD34*3t	4
11	PDCTF52201-11	HEX NUT	1/2"	4
12	PDCTF52201-12	IMPELLER	16"	1
13	PDCTF52201-13	MOTOR WASHER	3/4"*OD45*3t	1
14	PDCTF52201-14	MOTOR NUT	3/4"	1
15	PDCTF52201-15	MOTOR SUPPORT PLATE		1
16	PDCTF52201-16	HEX BOLT	5/16"*3/4"	12
17	PDCTF52201-17	FLAT WASHER	5/16"*OD18*2t	12
18	PDCTF52201-18	DUST CHUTE		1
19	PDCTF52201-19	CANISTER COVER PLATE		1
20	PDCTF52201-20	SHEET METAL THREAD BOLT	M4.2*12mm	12
21	PDCTF52201-21	COVER PLATE		2
22	PDCTF52201-22	SHEET METAL THREAD BOLT	M4.2*12mm	12
23	PDCTF52201-23	GEAR MOTOR		1
24	PDCTF52201-24	PHILIP HD BOLT	M5	4
25	PDCTF52201-25	LOCK WASHER	3/16"	4
26	PDCTF52201-26	FLAT WASHER	3/16"*OD12*1t	4

LAGUNA

Ref No	Part #	Part Name	Description	QTY
27	PDCTF52201-27	HEX BOLT	M5*65L	4
28	PDCTF52201-28	EYE BOLT	M16*25mm	4
29	PDCTF52201-29	FLAT WASHER	3/8*OD23*2t	4
30	PDCTF52201-30	HEX BOLT	3/8"*3/4"	8
31	PDCTF52201-31	FLAT WASHER	3/8"*OD23*2t	8
32	PDCTF52201-32	HEX BOLT	1/4"*3/4"	28
33	PDCTF52201-33	FLAT WASHER	1/4"*OD19*2t	28
34	PDCTF52201-34	DUST CHUTE SIDE PLATE	LONG	2
35	PDCTF52201-35	HEX BOLT	3/8"*3/4"	8
36	PDCTF52201-36	FLAT WASHER	3/8"*OD23*2t	8
37	PDCTF52201-37	HEX BOLT	1/4"*3/4"	12
38	PDCTF52201-38	FLAT WASHER	1/4"*OD19*2t	12
39	PDCTF52201-39	DUST CHUTE SIDE PLATE	SHORT	2
40	PDCTF52201-40	INTAKE CYLINDER	12"	1
41	PDCTF52201-41	FLAT WASHER	5/16"OD18*2t	4
42	PDCTF52201-42	HEX NUT	5/16"*3/4"	4
43	PDCTF52201-43	CYCLONE BARREL		1
44	PDCTF52201-44	HEX BOLT	5/16"*3/4"	12
45	PDCTF52201-45	FLAT WASHER	5/16"OD18*2t	12
46	PDCTF52201-46	HEX BOLT	5/16"*1-1/4"	12
47	PDCTF52201-47	FLAT WASHER	5/16"*OD18*2t	24
48	PDCTF52201-48	HEX NUT	5/16"	12
49	PDCTF52201-49	CYCLONE FUNNEL		1
50	PDCTF52201-50	CYCLONE FUNNEL VACUUM SUCTION TUBE		1
51	PDCTF52201-51	HEX BOLT	5/16"*3/4"	4

LAGUNA

Ref No	Part #	Part Name	Description	QTY
52	PDCTF52201-52	FLAT WASHER	5/16"*OD18*2t	4
53	PDCTF52201-53	FLEX HOSE	1-1/4"*730mm	1
54	PDCTF52201-54	HOSE CLAMP	1-1/4"	2
55	PDCTF52201-55	HEX BOLT	3/8"*1"	6
56	PDCTF52201-56	FLAT WASHER	3/8"*OD23*2t	12
57	PDCTF52201-57	HEX NUT	3/8"	6
58	PDCTF52201-58	DRUM VACUUM SUCTION TUBE		1
59	PDCTF52201-59	HEX BOLT	1/4"*3/4"	2
60	PDCTF52201-60	FLAT WASHER	1/4"*OD19*2t	2
61	PDCTF52201-61	DRUM LID		1
62	PDCTF52201-62	CANISTER FILTER	Ø600MM	1
63	PDCTF52201-63	HEX BOLT	5/16"*3/4"	12
64	PDCTF52201-64	FLAT WASHER	5/16"OD18*2t	12
65	PDCTF52201-65	SPRING BAG CLAMP	Ø600MM	1
66	PDCTF52201-66	CANISTER PLASTIC BAG		1
68	PDCTF52201-68	UPPER DRUM FRAME		1
69	PDCTF52201-69	SIDE DRUM PANELS		2
70	PDCTF52201-70	FRONT DRUM PANEL		1
71	PDCTF52201-71	QUICK RELEASE CLAMP		1
72	PDCTF52201-72	PHILIP HD BOLT	3/16"*3/8"	4
73	PDCTF52201-73	HANDLE LOCK NUT		1
74	PDCTF52201-74	HEX BOLT	1/4"*5/8"	1
75	PDCTF52201-75	HEX NUT	1/4"	1
76	PDCTF52201-76	VACUUM SUCTION RING		1
77	PDCTF52201-77	BACK DRUM PANEL		1

LAGUNA

Ref No	Part #	Part Name	Description	QTY
78	PDCTF52201-78	PHILIP HD BOLT	5/16"*5/8"	27
79	PDCTF52201-79	FLAT WASHER	5/16"*OD18*2t	27
80	PDCTF52201-80	HEX NUT	5/16"	27
81	PDCTF52201-81	DRUM VACUUM SUCTION TUBE		1
82	PDCTF52201-82	HEX BOLT	5/16"*3/4"	4
83	PDCTF52201-83	FLAT WASHER	5/16"*OD18*2t	8
84	PDCTF52201-84	FLEX HOSE	1-1/4"	1
85	PDCTF52201-85	HOSE CLAMP	1-1/4"	2
86	PDCTF52201-86	DRUM BASE PANEL		1
87	PDCTF52201-87	DRUM WHEEL	2"	4
88	PDCTF52201-88	FLAT WASHER	3/8"*OD23*2t	8
89	PDCTF52201-89	HEX NUT	3/8"	4
90	PDCTF52201-90	WINDOW		2
91	PDCTF52201-91	RIVET	3-2	20
91A	PDCTF52201-91A	FLAT WASHER	2.7"*OD6*1.5t	20
92	PDCTF52201-92	HEX NUT	5/16"	4
93	PDCTF52201-93	UPPER SUPPORT STAND	RIGHT	2
94	PDCTF52201-94	LOWER SUPPORT STAND	RIGHT	2
95	PDCTF52201-95	HEX BOLT	3/8"*1"	8
96	PDCTF52201-96	FLAT WASHER	3/8"*OD23*2t	16
97	PDCTF52201-97	HEX NUT	3/8"	8
98	PDCTF52201-98	UPPER SUPPORT STAND	LEFT	2
99	PDCTF52201-99	LOWER SUPPORT STAND	LEFT	2
100	PDCTF52201-100	FRONT LEFT COVER PLATE		1
101	PDCTF52201-101	HEX BOLT	3/8"*1"	10

LAGUNA

Ref No	Part #	Part Name	Description	QTY
102	PDCTF52201-102	FLAT WASHER	3/8"*OD23*2t	20
103	PDCTF52201-103	HEX NUT	3/8"	10
104	PDCTF52201-104	HORIZONTAL SUPPORT BRACE	LONG	2
105	PDCTF52201-105	HEX BOLT	3/8"*3/4"	8
106	PDCTF52201-106	FLAT WASHER	3/8"*OD23*2t	8
107	PDCTF52201-107	HEX BOLT	3/8"*1"	16
108	PDCTF52201-108	FLAT WASHER	3/8"*O23*2t	32
109	PDCTF52201-109	LOCK NUT	3/8"	16
110	PDCTF52201-110	HORIZONTAL SUPPORT BRACE	SHORT	2
111	PDCTF52201-111	HEX BOLT	3/8"*3/4"	8
112	PDCTF52201-112	FLAT WASHER	3/8"*OD23*2t	8
113	PDCTF52201-113	FRONT RIGHT COVER PLATE	FOR CONTROL PANEL	1
114	PDCTF52201-114	CONTROL BOX		1
115	PDCTF52201-115	CONTROL BOX SUPPORT PLATE		1
116	PDCTF52201-116	FLAT WASHER	5*16"*OD18*2t	4
117	PDCTF52201-117	HEX NUT	5/16"	4
118	PDCTF52201-118	HEX BOLT	1/4"*3/4"	6
119	PDCTF52201-119	FLAT WASHER	1/4"*OD19*2t	6
120	PDCTF52201-120	PHILIP HD BOLT	3/16"*3/8"	2
121	PDCTF52201-121	HEX BOLT	5/16"*5/8"	16
122	PDCTF52201-122	FLAT WASHER	5*16"*OD18*2t	32
123	PDCTF52201-123	HEX NUT	5/16"	16
124	PDCTF52201-124	CYCLONE FLANGE GASKET		2
125	PDCTF52201-125	FUNNEL FLANGE GASKET		1

LAGUNA

Ref No	Part #	Part Name	Description	QTY
126	PDCTF52201-1226	CONTROL PANEL		1
127	PDCTF52201-127	PHILIP HD BOLT	M4*10mm	6
128	PDCTF52201-128	ROTATION SHAFT		1
129	PDCTF52201-129	PADDLE		4
130	PDCTF52201-130	CANVAS		2
131	PDCTF52201-131	SHAFT SUPPORT BAR		1
132	PDCTF52201-132	SHEET METAL THREAD BOLT	3/16"*3/4"	14
133	PDCTF52201-133	HEX BOLT	1/4"*5/8"	8
134	PDCTF52201-134	FLAT WASHER	1/4"*OD13*1t	16
135	PDCTF52201-135	LOCK NUT	1/4"	8
136	PDCTF52201-136	HEX BOLT	5/16"*1-1/2"	1
137	PDCTF52201-137	FLAT WASHER	5/16"*OD18*2t	2
138	PDCTF52201-138	LOCK NUT	5/16"	1
139	PDCTF52201-139	GEAR MOTOR SHAFT		1
140	PDCTF52201-140	PHILIP HD BOLT	M4*10mm	2
141	PDCTF52201-141	HEX BOLT	M16*40mm	4
142	PDCTF52201-142	RUBBER SEAL	2.2M	1
143	PDCTF52201-143	TRIANGULAR SUPPORT PANEL		8
144	PDCTF52201-144	INTAKE ADAPTER	10" BY 4" X 4 PORT	1
145	PDCTF52201-145	RUBBER CAP	4"	3
146	PDCTF52201-146	PHLIP HD BOLT	M4*12mm	3
147	PDCTF52201-147	LOCK WASHER	1/2"	4
148	PDCTF52201-148	LOCK WASHER	3/8"	4
149	PDCTF52201-149	SILICONE		1
150	PDCTF52201-150	DEFLECTOR		1

LAGUNA

Ref No	Part #	Part Name	Description	QTY
151	PDCTF52201-151	CANISTER FILTER END CAP		1
152	PDCTF52201-152	WINDOW		1
153	PDCTF52201-153	RIVOT	3-2	10
153A	PDCTF52201-153A	FLAT WASHER	2.7*OD6*1.5t	10
154	PDCTF52201-154	FOAM TAPE	5*20mm*2M	1
155	PDCTF52201-155	LATCH	98#	4
156	PDCTF52201-156	ROUND HD BOLT	3/16"*3/8"	16
157	PDCTF52201-157	NUT	3/16"	16
158	PDCTF52201-158	RUBBER CAP	4"	1

LAGUNA

WARRANTY & REGISTRATION

Thank You!

Welcome to the Laguna Tools® group of discriminating industrial machinery owners. We understand that you have a choice of where to purchase your machines and appreciate the confidence you have in the Laguna Tools® brand.

Through hands-on experience, Laguna Tools® is constantly working hard to make innovative, precision products. Products that inspire you to create works of art are a joy to operate and encourage your best work.

Laguna Tools®
Imagination, Innovation, and Invention at Work

Warranty & Registration

Every product sold is warranted to be free of manufacturer's defective workmanship, parts, and materials. For any questions about this produce, the intended use or what it was designed for, customer service, or replacement parts, please contact our customer service department:

Laguna Tools® Customer Service
744 Refuge Way, Grand Prairie, Texas 75050, USA
1-800-234-1976
customerservice@lagunatools.com
www.lagunatools.com/why/customer-service/
8AM. To 5PM PSF. Monday through Friday

For warranty claims or to report damage upon receiving-please reach out to our warranty department:

Laguna Tools® Warranty Service
744 Refuge Way, Grand Prairie, Texas 75050, USA
1-800-234-1976
customerservice@lagunatools.com
www.lagunatools.com/policies/warranty
8AM to 5PM PST, Monday through Friday

Registration

To prevent voiding this warranty, all products sold must be registered within thirty (30) days of receiving the product. Registering the product will enable the original purchaser to receive notifications about important product changes, receive customer service, and be able to file a warranty claim against defective workmanship, parts, or materials.



Who is Covered

The applicable warranty covers only the initial purchaser of the product from the date of receiving the product. To file such claims, the original purchaser must present the original receipt as proof of purchase.

What is Covered

The warranty covers any defects in the workmanship of all parts and materials that make up the machine unless otherwise specified. Any part determined by Laguna Tools® to have a defect will be repaired or replaced (and shipped), without charge. The defective item/part must be returned to Laguna Tools® with the complaint and proof of purchase in the original packaging that it was received in. In the event the item/part is determined to be not covered by this warranty, the customer will be responsible for the cost to replace the item/part and all related shipping charges

Warranty Limitations

This limited warranty does not apply to natural disasters, acts of terrorism, normal wear and tear, product failure due to lack of maintenance or cleaning, damage caused by accident, neglect, or lack-of inadequate dust collection. The warranty may be voided against proof of misuse/abuse, damage caused where repair or alterations have been made or attempted by others, using the product for purposes other than those described as intended use (unless with consent by Laguna Tools®), modification to the product, or use with an accessory that was not designed for the product. It is the responsibility of the user to understand basic machinery settings and procedures and to properly maintain the equipment in accordance with the standards provided in this manual.

Length of Warranty

Machines sold for either commercial or industrial use have a one-year warranty. Wearable parts like throat plates, bandsaw guides, etc., have a ninety-day warranty.

Table A-1 Warranty Lengths

1 Year – Machines Sold for Commercial or Industrial Use
1 Year – Blades and Accessories outside or Machine Options
90 Days – Wearable Parts

Aside from being free of defects upon receiving, consumable parts, like cutters and abrasives, are not covered by this warranty unless otherwise stated by Laguna Tools®. These parts are designed to be used at the expense of the operator and are available for replacement or inventory purchase. The determination of a consumable part will be made on a case-by-case basis by Laguna Tools®.

Shipping Damage

Laguna Tools® is not responsible for damage or loss caused by a freight company or other circumstances not in the direct control of Laguna Tools®. All shipping-related claims for loss or damage to goods must be made to Laguna Tools® within twenty-four hours of delivery.

How to Receive Support

To file a warranty-claim please contact the warranty department at 1-800-234-1976. To receive customer service or technical support please contact the customer service or technical support please contact the customer service department at 1-800-332-4049. Parts, under warranty, are shipped at the expense of Laguna Tools® either by common carrier, FedEx ground services or similar method. Technical support to install replacement parts is primarily provided by phone, fax, email, or the Laguna Tools® Customer Service Support Website.



© 05/2023 Laguna Tools, Inc.

LAGUNA

NOTES

LAGUNA

NOTES

LAGUNA

www.lagunatools.com

061124