

# Jointer Manual



LAGUNA

LAGUNA TOOLS  
2072 Alton Parkway  
Irvine, California 92606  
Ph: 800.234.1976  
[www.lagunatools.com](http://www.lagunatools.com)

Model Numbers: MJO6405-0800  
MJO6012-0800-3phCSA  
MJO6012-0800-1phCSA



## Table of contents

	<b>Page number</b>
<b>Safety Rules</b>	<b>4</b>
<b>Warranty</b>	<b>5</b>
<b>Noise emission</b>	<b>6</b>
<b>Specification sheet</b>	<b>6</b>
<b>Receiving your jointer</b>	<b>6</b>
<b>Introduction to your jointer</b>	<b>7</b>
<b>What you receive with jointer</b>	<b>8</b>
<b>Parts of the jointer</b>	<b>9</b>
<b>Where to locate your jointer</b>	<b>10</b>
<b>Unpacking and assembling your jointer</b>	<b>10</b>
<b>Assembly and set up ???</b>	<b>12</b>
<b>Running &amp; adjusting the jointer</b>	<b>13</b>
<b>Maintenance</b>	<b>17</b>
<b>Troubleshooting and fault finding</b>	<b>18</b>
<b>Electrical drawings</b>	<b>22</b>
<b>Exploded view drawings</b>	<b>23</b>

### **Safety Rules**

**As with all machinery there are certain hazards involved with the operation and use of your machine. Using it with caution will considerably lessen the possibility of personal injury. However, if normal safety precautions are overlooked or ignored, personal injury to the operator may result. If you have any questions relating to the installation and operation, do not use the equipment until you have contacted your supplying distributor.**

**Please read the following carefully before operating the machine:**

- 1. Keep the working area clean and ensure adequate lighting is available.**
- 2. Do not wear loose clothing, gloves, bracelets, necklaces or ornaments.**
- 3. Do wear face, eye, respiratory and body protection devices as indicated for the operation or environment.**
- 4. Ensure that the power is disconnected from the machine before tools are serviced or an attachment is to be fitted or removed.**
- 5. Never leave the machine with the power on.**
- 6. Do not use dull, gummy or cracked cutting tools.**
- 7. Ensure that the keys and adjusting wrenches have been removed and all the nuts and bolts are secured.**

# Limited Warranty

New machines and accessories sold by Laguna Tools carry a one-year warranty effective from the date of shipping. Machines sold through dealers must be registered with Laguna Tools within 30 days of purchase to be covered by this warranty. Laguna Tools guarantees all new machines and accessories sold to be free of manufacturers' defective workmanship, parts and materials. We will repair or replace, without charge, any parts determined by Laguna Tools, Inc. to be a manufacturer's defect. We require that the defective item/part be returned to Laguna Tools with the complaint. Any machines returned to Laguna Tools must be returned with packaging in the same manner in which it was received. If a part or blade is being returned it must have adequate packaging to ensure no damage is received during shipping. In the event the item/part is determined to be damaged due to lack of maintenance, cleaning or misuse/abuse, the customer will be responsible for the cost to replace the item/part, plus all related shipping charges. This limited warranty does not apply to natural disasters, acts of terrorism, normal wear and tear, product failure due to lack of maintenance or cleaning, damage caused by accident, neglect, lack of or inadequate dust collection, misuse/abuse or damage caused where repair or alterations have been made or attempted by others.

Laguna Tools, Inc. is not responsible for additional tools or modifications sold or performed (other than from/by Laguna Tools, Inc.) on any Laguna Tools, Inc. machine. Warranty maybe voided upon the addition of such described tools and/or modifications, determined on a case-by-case basis.

Software purchased through Laguna Tools Inc. is not covered under this warranty and all technical support must be managed through the software provider. Software is non-refundable.

Normal user alignment, adjustment, tuning and machine settings are not covered by this warranty. It is the responsibility of the user to understand basic machinery operation, settings and procedures and to properly maintain the equipment in accordance with the standards provided by the manufacturer.

Parts, under warranty, are shipped at Laguna Tools, Inc.'s cost either by common carrier, FEDEX ground service or a similar method. Technical support to install replacement parts is primarily provided by phone, fax, e-mail or Laguna Tools Customer Support Website. The labor required to install replacement parts is the responsibility of the user.

Laguna Tools is not responsible for damage or loss caused by a freight company or other circumstances not in our control. All claims for loss or damaged goods must be notified to Laguna Tools within twenty-four hours of delivery. Please contact our Customer Service Department for more information.

Only **new** machines sold to the original owner are covered by this warranty. For warranty repair information, **call 1-800-332-4094**.



## **Noise emission**

Notes concerning noise emission:

Given that there exists a relationship between noise level and exposure times, it is not precise enough to determine the need for supplementary precautions. The factors affecting the true level of exposure to operators are clearly the amount of time exposed; the characteristics of working environment; other sources of dust and noise etc. For example, adjacent machines may impact the level of ambient noise. It is also possible that exposure level limits will vary from country to country.

## **Specification.**

<b>Machine</b>	<b>MJO6405-0800</b>	<b>MJO6012-0800-3phCSA</b>	<b>MJO6012-0800-1phCSA</b>
<b>Motor</b>	5 hp / single or 3 phase [5000 rpm]	3 hp / single or 3 phase [5000 rpm]	3 hp / single or 3 phase [5000 rpm]
<b>Fence tilt</b>	90 to 45 degrees	90 to 45 degrees	90 to 45 degrees
<b>Dust chute diameter</b>	5 inches	5 inches	5 inches
<b>Max cutting depth</b>	0.3 inch [8mm]	0.3 inch [8mm]	0.3 inch [8mm]
<b>Max cutting width</b>	16 inches [400 mm]	12 inches [305 mm]	12 inches [305 mm]
<b>Table [L x W x H]</b>	97.6 inches x 10.28 inches x 4.13 inches [2480mm x 405mm x 105mm]	79.5 inches x [2019mm x]	79.5 inches x [2019mm x]
<b>Cutter head</b>	Insert tooth 4.33 inches dia [110mm dia]	Insert tooth 4 inches dia [100mm dia]	Insert tooth 4 inches dia [100mm dia]
<b>Volts</b>	220Volts single or 3 phase	220Volts single or 3 phase	220Volts single or 3 phase
<b>Weight net/gross</b>	1254 lb / 1386 lb [570 kg / 630 kg]	968 lb / 1078 lb [440 kg / 490 kg]	968 lb / 1078 lb [440 kg / 490 kg]

## **Receiving your machine**

**Note:** It is probable that your machine will be delivered by a third party. Before you unpack your new machine, you will first need to inspect the packing, invoice, and shipping documents supplied by the driver.

Ensure that there is no visible damage to the packing, or the machine. You must do this prior to the driver leaving. All damage must be noted on the delivery documents and signed by you, and the delivery driver. You must then contact the seller, [Laguna Tools, Inc.] within 24 hours.

## **Introduction to jointer**

The jointer is designed to give you years of safe service. Read this owner's manual in its entirety before assembly or use.

The jointer is generally defined as a machine that cuts planks of wood flat, and smooth. The machine achieves this by the plank being pushed along a flat table, and passing the plank over a revolving cutter head.

There are many types of cutter head, and this machine uses an inserted cutter type. The insert cutters main advantage is to reduce tear out of the grain, but the finish is not as smooth as the parallel blade system. It is well within the capabilities of a belt sander to give a professional finish to the jointed plank.

The parallel blade system gives a finish without the lines that the insert cutter system gives, but, is susceptible to tear out, especially on planks with knots. On balance, it is better to use a machine with the insert cutters than the parallel blades, as it greatly reduces the risks of having to scrap valuable wood, or to spend excessive time sanding tear out marks.

## **Additional instructions for the use of the jointer**

Like all machines, there is danger associated with the machine. Injury is frequently caused by lack of knowledge or familiarity. Use this machine with respect. If normal safety precautions are overlooked or ignored, serious personal injury may occur.

### **1. Kickback**

"Kickback" is when the work piece is thrown off the jointer table by the cutter head. Always use push blocks and safety glasses to reduce the likelihood of injury from "kickback". The "kickback zone", is the path directly through the end of the in feed table. Never stand or allow others to stand in this area during operation. If kick back occurs, severe injury may occur.

### **2. Cutter head alignment**

To reduce the possibility of kickback, keep the top edge of the out feed table aligned with the cutter head insert at top dead centre (TDC).

### **3. Push blocks**

The cutter heads are extremely dangerous and you must never pass your hands over the cutter head. Always use push blocks when surface planing.

#### **4. Supporting the work**

Only make cuts if the work piece is stable and never attempt to cut unstable planks, or injury may occur.

#### **6. Cutting depth**

Never exceed the maximum cutting depth as stated in the specification for your machine. It is far better to take several small cuts rather than one large cut.

#### **7. Direction of cut**

Jointing against the grain or jointing end grain is dangerous and could produce chatter or excessive chip out. Always joint with the grain.

#### **8. Guards**

Guards are designed to reduce the risk of injury. Always use the guards. If it is imperative to use the machine without the guards, [Rabbeting] always replace the guards immediately afterwards.

#### **9. Cutting direction**

Only cut from the in feed table to the out feed table, and always complete the cut. Do not stop the wood progress until the job has cleared the cutter head completely. Only cut with the grain or at a slight angle to the grain.

#### **10. Stock**

Your safety will be greatly enhanced if you only use good lumber. Only work with lumber after you have inspected it completely. Staples, nails loose knots and any metal in the plank will damage your cutter head and could cause injury and or fire. If you have any concerns about a piece of lumber, do not use it.



## What you will receive with the jointer

Spare teeth screws

Spare cutter teeth



Tools

Cutter teeth screw driver



Fence assembly

## Parts of the jointer

### Out feed Table

The function of the out feed table is to support the job once it has been machined by the cutter head. The out feed table must be adjusted level with the cutter head teeth at top dead centre [TDC].

### In feed Table

The in feed table is adjusted to suit the depth of cut that is required.

**Note:** Never exceed the maximum depth of cut specified for your machine. It is far safer to take many small cuts rather than one large cut.

### **Fence**

The fence is used to keep the job square to the cutter head and is also used to produce angle cuts on the edges of panels. The fence can be adjusted from 90 to 45 degrees.

### **Cutter head Guard**

The guard is there to protect you. Always adjust the guard to expose only the minimum amount of cutter to suit the job width.

### **Dust port**

The dust port is designed to allow maximum extraction of saw dust and wood chippings. Connect a 5" flexible dust collection hose between the machine and your dust extraction system.

**Note:** The stronger the dust collector the better.

### **Table height adjusting handles**

The hand wheels adjust the tables to the required height.

### **Body**

The body of the machine supports the table etc. It provides a heavy base that is designed for rigidity.

### **Start & stop switches**

These switches are used to start and stop the machine.

### **Serial and data plate**

This plate is mounted on the back of the machine.

### **Where to locate your Machine**

Before you unpack your machine select the area where you will use your machine. There are no hard and fast rules for its location, but below are a few guidelines.

1. There should be an area around the machine suitable for the length of wood that you will be machining.
2. Adequate lighting. The better the lighting, the more accurately and safely you will be able to work
3. Solid floor. You should select a solid flat floor, preferably concrete or something similar.
4. Locate the machine close to the power source and dust collection.

## Unpacking and assembling your jointer

To unpack your machine, you will need tin snips, knife and a wrench.

**Note:** The jointer, fence and control console are heavy, and if you have any doubt about the described procedure, seek professional assistance. Do not attempt any procedure that you feel is unsafe, or that you do not have the physical capability of achieving.

1. Using the tin snips, cut the banding that is securing the machine to the Pallet [if fitted].

**WARNING: EXTREME CAUTION MUST BE USED AS THE BANDING WILL SPRING AND COULD CAUSE INJURY.**

2. Open the box.

3. Remove the transport bolts that secure the jointer to the base of the box.

4. Remove the securing straps that secure the control console to the base of the box and remove the plastic wrapping.

5. **Note:** You will need at least two people to attach the control console to the jointer.

6. Remove the fixing screws at the back of the jointer.



**Packaged jointer**



**Packaged jointer with the box removed**



**Transport bolt**



**Control console**

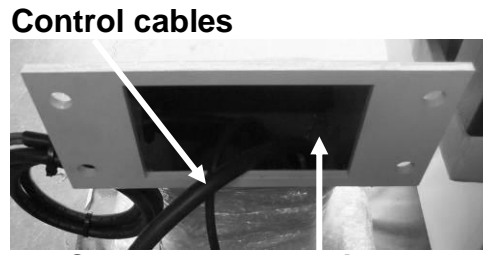

**Control cables**

**Control console with the wrapping removed**

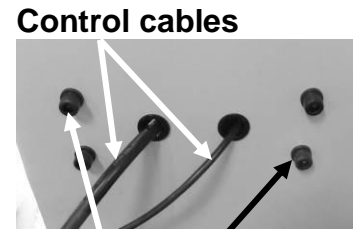

**Control cables**

**Control console fixing screws**

7. Lift the control console so that it lines up with the fixing screws. While you are lifting it into place, feed the cables through into the body of the jointer. Prior to attaching the control console check that neither of the cables are under the mounting flange. Secure in position with the fixing screws.

8. Remove the fixing straps that secure the fence to the base of the box. Lift the fence off the box and put to one side.

9. The jointer is now ready to be lifted off the base of the box.

10. Remove the jointer from the box base with a fork lift of sufficient capacity. The jointer weighs 1254lb [570 kg] [dependant on the machine purchased]. Remove the box base and lower the jointer to the floor.

11. Remove the cutter guard by loosening the clamp screw and lifting it out.

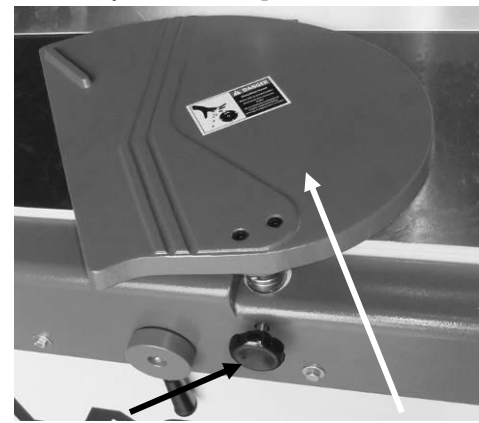

**Clamp screw**

**Cutter guard**

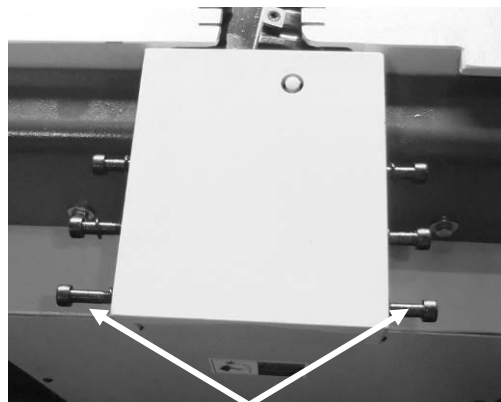

**Side fixing screws**

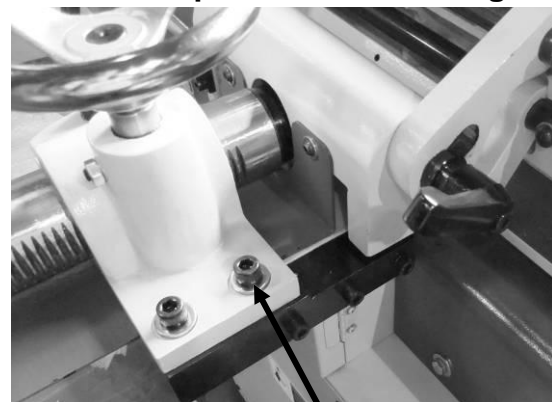

**Casting mounting screws**

**11.** Remove the side fixing screws from the jointer.

**12.** Loosen two casting mounting screws to loosen one of the black clamp blocks. It is not important which side you choose. By loosening the clamping block it will be a lot easier to attach the fence.

**13.** Lift the fence [this will take at least two people as the fence is very heavy] and fit onto the jointer. Fit the side fixing screws and tighten the side that was not loosened. Snug tight the other side [loose casting mounting bolts]. Tighten the casting mounting bolts then fully tighten the side mounting bolts.

**14.** Refit the cutter guard. When assembled, the guard should move back to cover the cutter head by the action of the spring. To obtain a smooth action it is recommended that the guard is just above the table. This will remove the friction of the guard rubbing on the table.



**Cutter guard**

**15.** Connect a 5" flexible hose between the dust hose connector and your dust collector. Once fitted pull on the hose to ensure that the connection is tight.

**Note:** You will need a dust collection system with a minimum of 1000 cubic feet per minute capacity. The stronger the dust collection, the better as the machine is capable of producing a lot of waste.

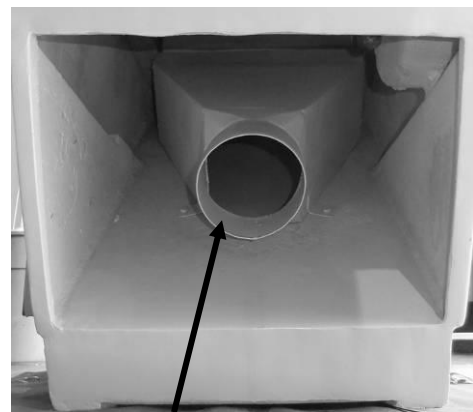

**Dust hose connector**

The jointer is now fully assembled but before the machine is connected to the electrical supply the following checks and adjustments must be carried out.

- 1.** Check that the cutter head can rotate freely and that the teeth do not contact with either the in or the out feed tables.
- 2.** Check that the guard is covering the cutter head and that it is free to move and spring back once released.
- 3.** Check that all tools have been removed from the machine.

### **Connecting the electrical supply**

**Note:** A qualified electrician must carry out the installation.

Ensure that the main supply corresponds with that of the machine.

It is recommended that you use a 30-amp mains breaker.

**Note:** The machine is not supplied with an electrical plug, as the type of plug will be dependent on your installation.

## Running and adjusting the jointer

### Cleaning the jointer

The machine is shipped with non painted surfaces protected from rust by a film of grease.

The grease must be removed with WD40 or similar as grease attracts saw dust and dirt. The surfaces should then be coated with a Teflon lubricant or similar. Teflon tends to dry and will not attract saw dust and dirt.

### Test Run

Now that the assembly is complete it is time to conduct a test run.

During the test run you will check the following points:

1. Motor starts and runs smoothly.
2. The stop button functions correctly.

Before you run the machine check the following:

1. All tools have been removed from the machine.
2. T guard is in place.
3. You are wearing the appropriate safety equipment.
4. You have read and understood the instruction manual.

**Note:** If any of the below functions fail to operate correctly, the fault must be corrected prior to continuing to the next test. Any investigation to find or correct a

### **Power on indicator light**



**Emergency stop button**

**Start button**

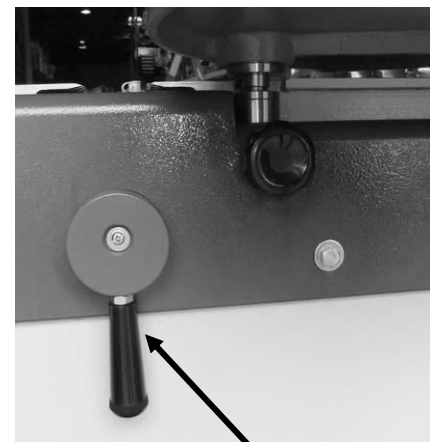

**Stop lever**

fault must be conducted with the power disconnected.

1. Check that the red stop button is fully out. To release the red stop button twist clock wise. When the emergency stop button is pressed, it latches in and needs to be re-set
2. Start the machine by pressing the green start button.  
The machine should run smoothly with little or no vibration.
3. Press the red emergency stop button. The machine should slow down and stop.
4. Reset the emergency stop button.
5. Start the machine by pressing the green start button.

6. Push the stop lever [direction either left or right]. The machine should slow down and stop.

### **Adjustments:**

**Note:** The machine has had all its functions calibrated at the factory but during shipping some movement may have taken place. This is unavoidable and it is therefore recommended that the following checks are made prior to starting production. As the machine is used, some functions may require adjustment and it is therefore good practice to know the process for adjusting the machine prior to production.

### **Setting the out feed table to the cutter head**

The out feed table must be level with the teeth of the cutter head when the teeth are at top dead centre [T.D.C.]

1. Rotate the cutter head so that the teeth are at the T.D.C. position.
2. Place a straight edge on the out feed table over the cutter head and check that the teeth just touch the straight edge.

**Note:** This should be checked from both sides of the table.

### **Setting the in feed table**

1. Place a straight edge so that it is equal on both the in feed and out feed tables.
2. Bring the in feed table up so that the straight edge is even on both tables.
3. Check that the table is lined up with the scale at "0".

### **Fitting teeth to the Sher Tec cutter head**

The carbide cutter head [Sher Tec] has multiple teeth, each of which, have 4 cutting edges. The teeth can be rotated as follows when they are blunt or damaged.

**Note:** You will notice that each cutter tooth has a registration dot to enable you to ensure that the teeth are moved round in the same direction.

1. Loosen the tooth with the allen key provided.



**Table adjusting handle**

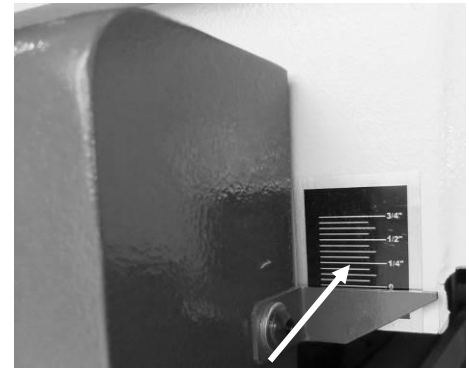

**In feed table depth of cut scale**

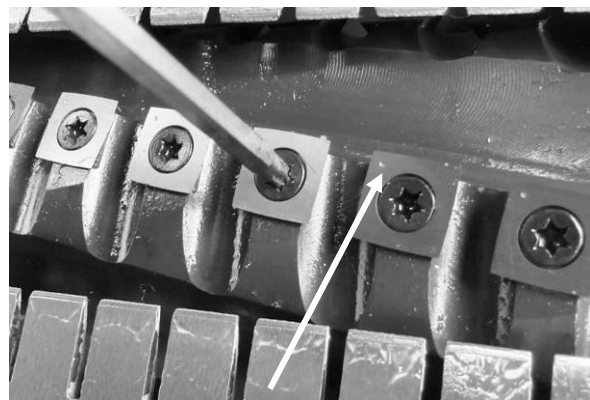

**Registration dot**

2. Lift the tooth and rotate to the new cutting face.

**Note:** Take special care to clean the tooth and its matching surface. Any dirt or sawdust that is trapped under the tooth will cause it to be at a different height to the other teeth, and will degrade the surface finish when you start machining. This will result in you having to take all the teeth out and clean both the teeth and the matching surfaces again. This is very frustrating, and a waste of time. Take your time and ensure that you are very thorough with cleaning.

3. Lower the tooth into the cutter head and clamp with the allen key.

**Note:** ALWAYS move ALL the teeth to a new cutting edge. NEVER move less than all the teeth.

**Note:** The carbide cutter head has several advantages over the parallel blade type cutter head.

1. The teeth are carbide and will last longer than high speed steel parallel blades.

2. There is less chance of tear out.

The disadvantage is that they are initially more expensive and the surface finish is slightly wavy. This is because the teeth have a very slight radius. This waviness is easily removed by a light sanding.

### Adjusting the fence

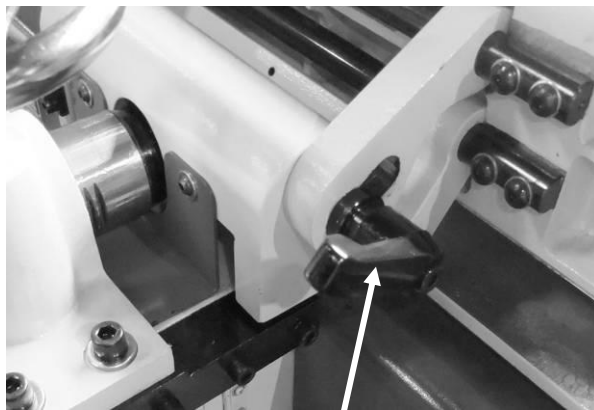

**Angle clamp handle**

**Forward / back adjusting handle**



**Clamp handle**

The fence can be adjusted to any angle between 90 and 45 degrees. To adjust the angle, loosen the clamp handle, move the fence to the required angle and clamp in position.

The fence has 2 adjustable stops, one for 45 degrees and the other stop for the 90 degree position.



The stops come pre-set, but should adjustment be required, see the guide lines below.

### **Adjusting the 45 degree stop**

1. Adjust the fence to 45 degrees using a set square, and lock in position.
2. Adjust the stop screw so that it touches the back of the fence and lock in position with the lock nut.
3. Unlock the fence and move. Move the fence back to the 45 degree stop and lock in position. Check that the fence is at 45 degrees. If the fence is not at 45 degrees, readjust.



**45 degree stop screw and lock nut**

### **Adjusting the 90 degree stop**

1. Adjust the fence to 90 degrees using a set square, and lock in position.
2. Adjust the stop screw so that it touches the back of the fence, and lock in position with the lock nut.
3. Unlock the fence and move. Move the fence back to the 90 degree stop and lock in position. Check that the fence is at 90 degrees. If the fence is not at 90 degrees, readjust.

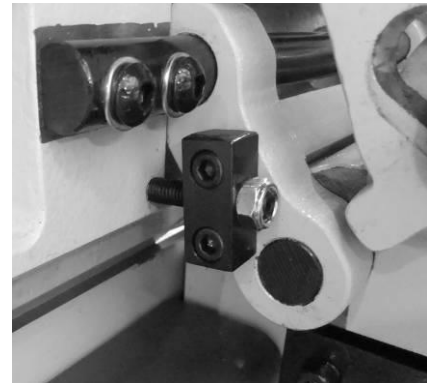

**90 degree stop screw and lock nut**

### **Maintenance**

As with any machine, to ensure optimal performance you must conduct regular maintenance.

### **Bearings**

Most of the bearings are sealed and require no lubrication.

The following should be lubricated every 80 hours of use.

### **Cutter head**

The cutter head has two bearings that required greasing. There are white stickers pointing to their general location. There are two grease fittings, one at each end of the cutter head. The grease fitting on the front side of the jointer is located in a small hole cut into the top of the front base housing. The grease fitting on the back side of the machine is located on the top of the jointer base just under the bottom edge of the fence.



**Grease point**

### **Hand wheel**

Each hand wheel is lubricated via an oil cup located just behind the hand wheel body on the axle collar. Remove the hand wheel lock knob and slide the hand wheel off the axle. This will reveal the oil cup. Apply a small amount of light machine oil.

### **Table lifting mechanism**

The table lifting mechanism screw and gear for each hand wheel can be accessed by removing the left and right rear base housing. Apply a generous amount of grease to both the screws and the gears.

### **Daily checks**

1. Clean the machine and lubricate unpainted surfaces with a Teflon lubricant. Wipe off any excess and buff with a dry polishing cloth. This will reduce the likelihood of rust forming and reduce the friction on the tables as the wood is machined.
2. Check cutter teeth for chips and dullness.
3. Generally inspect the machine for damage and loose or worn parts.

### **Weekly checks**

1. Clean the cutter head.
2. Check cutter teeth for chips and dullness.
3. Generally inspect the machine for damage and loose or worn parts.
4. Check the dust extraction for blockages and any large bits that could cause blockages.

### **Monthly checks**

1. Check the motor drive belts for wear, splits and cuts.
2. Clean the motor compartment and the motor to ensure that the motor cooling fins work efficiently.
3. Generally inspect the machine for damage and loose or worn parts.

**Note:** It is recommended that you use a Teflon based lubricant.

### **Drive belt replacement**

**Note:** Your machine is fitted with a double drive belt system. Always replace both belts with a matched set. Never replace only one belt as this will cause vibration, excessive wear to bearings and result in a poor work finish.

**Note:** Disconnect the power to the machine.

1. Remove the side cover.
2. Loosen the motor clamping bolts.
3. Remove the drive belts.
4. Fit the new belts.
5. Re-tension the belts. There should be a 3/16" deflection when the belt is pressed with moderate finger pressure. Tighten the motor clamping bolts.
6. The drive belts should be checked after running the machine for approximately 10 hours. The belts bed into the pulleys and will slacken off slightly. If they are not

adjusted slippage may happen and this will cause early belt failure. There should be a 3/16" deflection when the belt is pressed with moderate finger pressure.

7. Refit the side cover before running the machine.

### **Troubleshooting and fault finding**

Problem	Cause	Corrective action
Motor will not start or fuses or circuit breakers blow.	1. Short circuit.	1. Repair or replace short circuit item.
	2. Start capacitor faulty.	2. Fit new capacitor.
	3. Motor thermal protection circuit breaker faulty, or motor is at fault.	3. Replace thermal protection circuit breaker in motor or replace motor.
	4. Open circuit in motor or loose connections.	4. Replace or repair motor or loose connection
Fuses or circuit breakers blow.	1. Motor drawing excessive current.	1. Repair or replace motor.
	2. Cutter head or motor jammed.	2. Remove jam.
	3. Short circuit.	3. Repair or replace short circuit item.
Motor will not develop full power or motor speed slows with load, overheats, or stalls.	1. Motor run capacitor at fault.	1. Replace the capacitor.
	2. Machine overloaded.	2. Take smaller cuts.
	3. Motor overheating.	3. Clean motor taking care to ensure that all the cooling fins are clean.
	4. Short circuit in motor or loose connections.	4. Repair or replace motor / loose connections.
Cutter head slows or belt squeals when cutting.	1. V-belts loose.	1. Tighten V-belts
	2. V-belts worn out.	2. Replace V-belts
Loud noise coming from machine.	1. Drive belts are damaged.	1. Replace drive belts.
Tables are hard to	1. Table spindles are	1. Clean and lubricate

adjust.	tight.	spindles.
Excessive snipe (gouge in the end of the board that is uneven with the rest of the cut).	1. Out feed table is too low.	1. Re-set out feed table with cutter head.
	2. Operator pushing down on trailing end of job.	2. Eliminate downward pressure on trailing end of job.
	3. Job is not supported as it leaves the out feed table.	3. Support the job as it leaves the out feed table.
Job stops or slows during cut.	1. Taking too deep cut.	1. Take smaller cuts.
	2. Pitch or build up on tables.	2. Clean the tables and cutter head components
Chipping or marks (consistent pattern).	1. Knots or conflicting grain direction in wood.	1. Inspect job for knots and grain direction; only use good material.
	2. Nicked, chipped or dull carbide tooth.	2. Replace/rotate affected tooth.
	3. Taking too deep cut.	3. Take smaller cuts. Take small cuts on hard woods.
Furry finish on the grain.	1. Wood has high moisture content or surface wetness.	1. Check moisture content and allow to dry.
	2. Blunt teeth.	2. Rotate the teeth.
Lines or ridges that run along the board.	1. Nicked or chipped teeth.	1. Replace or rotate teeth.
Chatter marks across the face of the board. Uneven teeth marks, or wavy surface.	1. Teeth not at even heights.	1. Clean interface between teeth and cutter head.
	2. Teeth not installed evenly.	2. Check that there is no dirt etc. under the teeth and that they are evenly tight.
	3. Worn cutter head bearings.	3. Replace cutter head bearings.
Shiny finish.	1. Teeth are blunt.	1. Rotate/replace teeth.

	2. Too fine a cut.	2. Increase the depth of cut.
Chip marks, random pattern.	1. Chips not removed from cutter head.	1. Use a dust collection system. Or a stronger dust collection system
Board edge is concave or convex after jointing.	1. Job not held with even pressure on in feed and out feed table during cut.	1. Hold job with even pressure as it moves over the cutter head.
	2. Job started too uneven.	2. Take small cuts to remove the extreme high spots before doing a full pass.
	3. Board has excessive bow or twist along its length.	3. Surface plane one face so there is a good surface to position against the fence.
	4. Insufficient number of passes.	4. It may take 3 to 5 passes to achieve a good edge, depending on starting condition of board and depth of cut.

## Electrical drawings

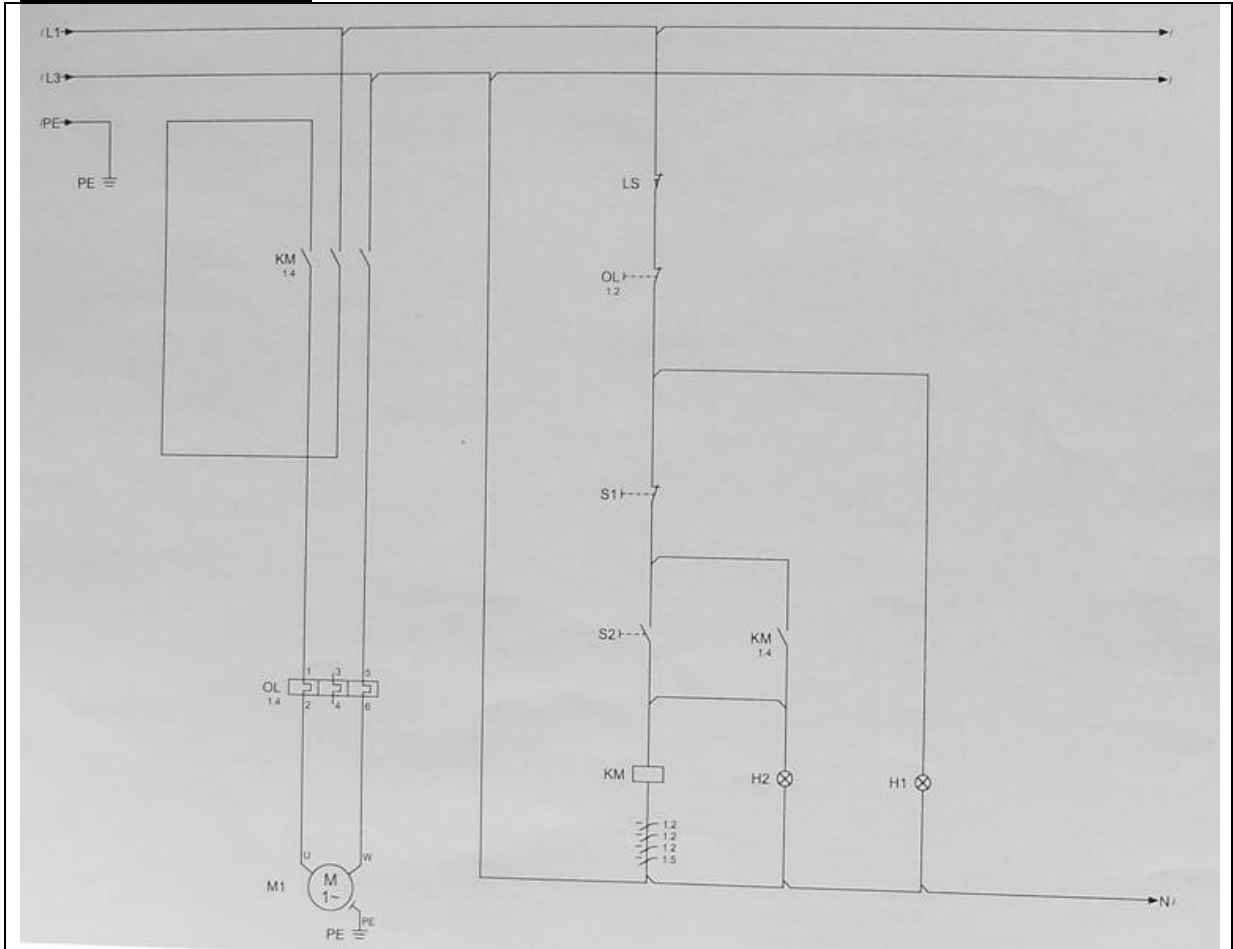

## Exploded view drawings

Index No.	QTY	Part No.	Chinese name	Description	Size
1	1	405S001A	底座組立	SEAT ASSEMBLE	
2	1	405S020	平板組立	RIGHT PLATE	
3	1	405S024	平板組立	LEFT PLATE	
4	2	500S017	平板升降組立	PLATE ELEVATION ASSEMBLE	
5	1	405SS027EG	鉋仁組立	CUTTER HEAD ASSEMBLE	
6	1	405SS066B	靠板組立	ALUMINUM FENCE ASSEMBLE	
7	1	405S045	鉋仁護蓋組立	CUTTER HEAD COVER	
8	1	500S083A	馬達組立	MOTOR ASSEMBLE	



Date	2010/6/18	Draw No	CM-405E-LAGUNA
Scale	1:20	Draw Name	MACHINE ASSEMBLY

Index No.	Qty	Part No.	Chinese name	Description	Size
1	1	40S001	底座	BASE	
2	4	40SG006	平板長軸心	FLAT LONG SPINDLE	
3	1	40SG011A	前蓋板	FRONT PLATE	
4	1	40SG008	左後蓋板(短)	LEFT REAR PLATE	
5	1	40SG009	右後蓋板	RIGHT REAR PLATE	
6	1	500076	底座蓋板	BASE REAR COVER	
7	1	500055	電器箱	ELECTRIC BOX	
8	8	500052	套環	STOP CLAW FIXED RING	
9	1	303003E	平板升降扭動臂	FLAT LIFTING TWISTING ARM(RIGHT)	
10	4	303005	平板支撐雙孔粒	FLAT-SUPPORT SPECTACLE GRANULE(LEFT)	
11	2	303005A	平板支撐雙孔粒	FLAT-SUPPORT SPECTACLE GRANULE(LEFT)	
12	1	303003L	平板升降扭動臂	FLAT LIFTING TWISTING ARM(LEFT)	
13	1	303047	轉盤支座	PROTECTION ALUMINUM COVER SEAT	
14	1	40S077	吸風管	DUST HOOD	
15	2	A10130	六角頭螺絲	HEX HEAD BOLT	
16	2	ARE10	螺帽	HEX NUT	(M10)

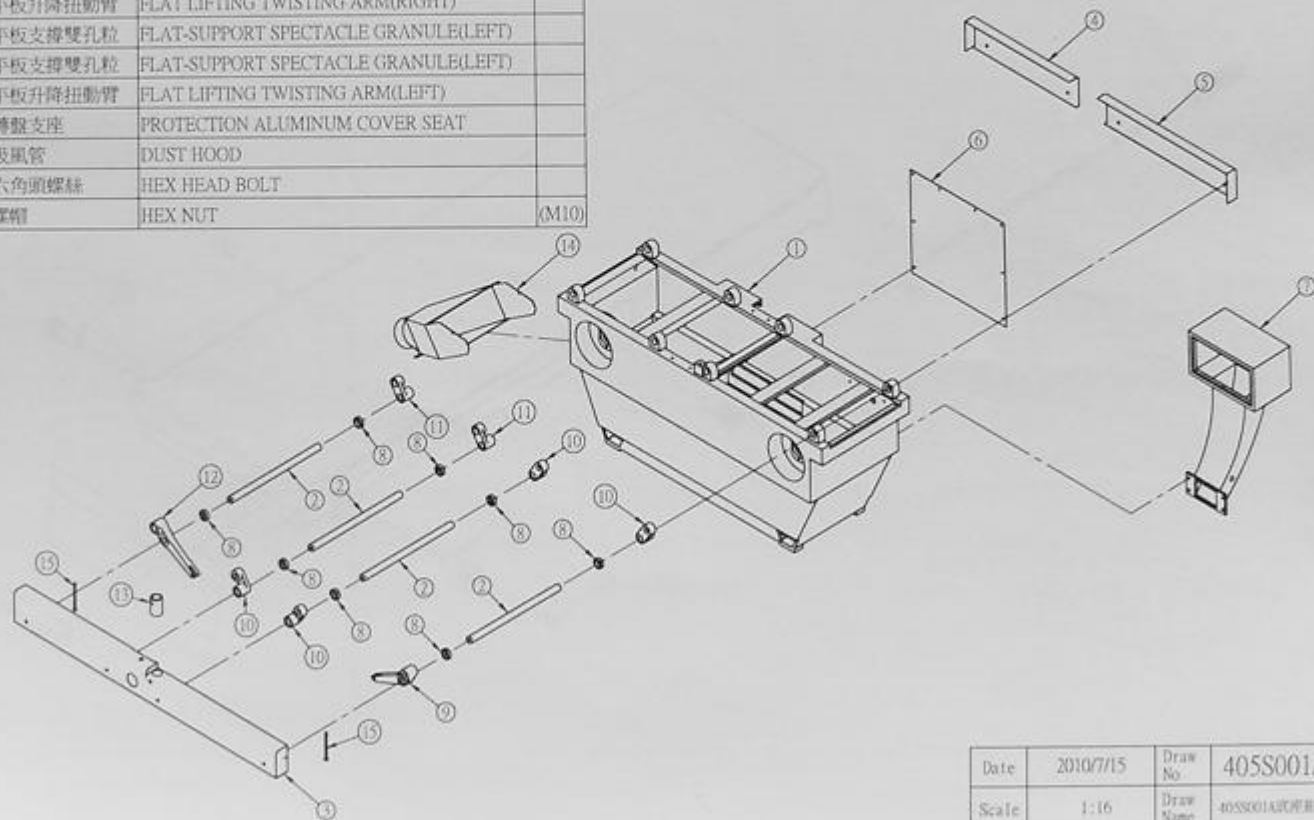

Date	2010/7/15	Draw No.	40SS001A
Scale	1:16	Draw Name	40SS001A/POWER/RELI



Index No.	Qty	Part No.	Chinese name	Description	Size
1	1	405020	平板	RIGHT PLATE (LONG)	
2	1	405022A	平板前消音板	FRONT COVER SILENCE	
3	1	405023	遮屏板	COVER	
4	4	767049B	彈簧板偏心軸	TORSION(SHORT)	
5	4	767087	六角穴螺絲	HEX CAP BOLT	
6	1	405026	勾桿	ROD(LONG)	
7	1	500025	勾桿彈簧	ROD SPRING	d:4.2 D:26 L:129 N:13

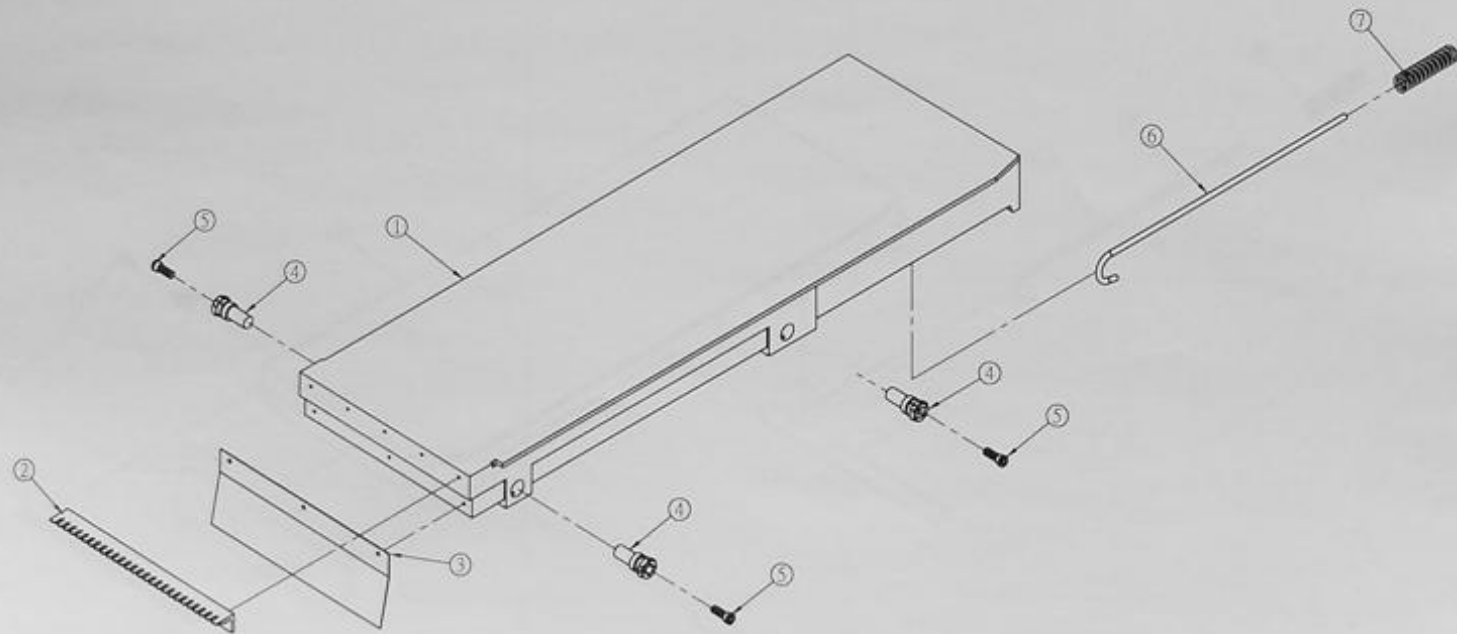

Date	2009/9/25	Draw No.	405S020
Scale	1:6.5	Draw Name	405S020平板組立

Index No.	Qty	Part No.	Chinese name	Description	Size
1	1	405024	平板	RIGHT PLATE (LONG)	
2	1	405022A	平板前消音板	FRONT COVER SILENCE	
3	1	405023	遮層板	COVER	
4	1	767049B	壓鉤板偏心軸	TORSION(SHORT)	
5	1	405G007	平板長軸心	FLAT LONG SPINDLE	
6	1	303G007A	平板長軸心	FLAT LONG SPINDLE	
7	1	767087	六角穴螺絲	HEX CAP BOLT	
8	1	405026A	勾桿	ROD(LONG)	
9	1	500025	勾桿彈簧	ROD.SPRING	ø:4.2 D:26 L:129 N:13

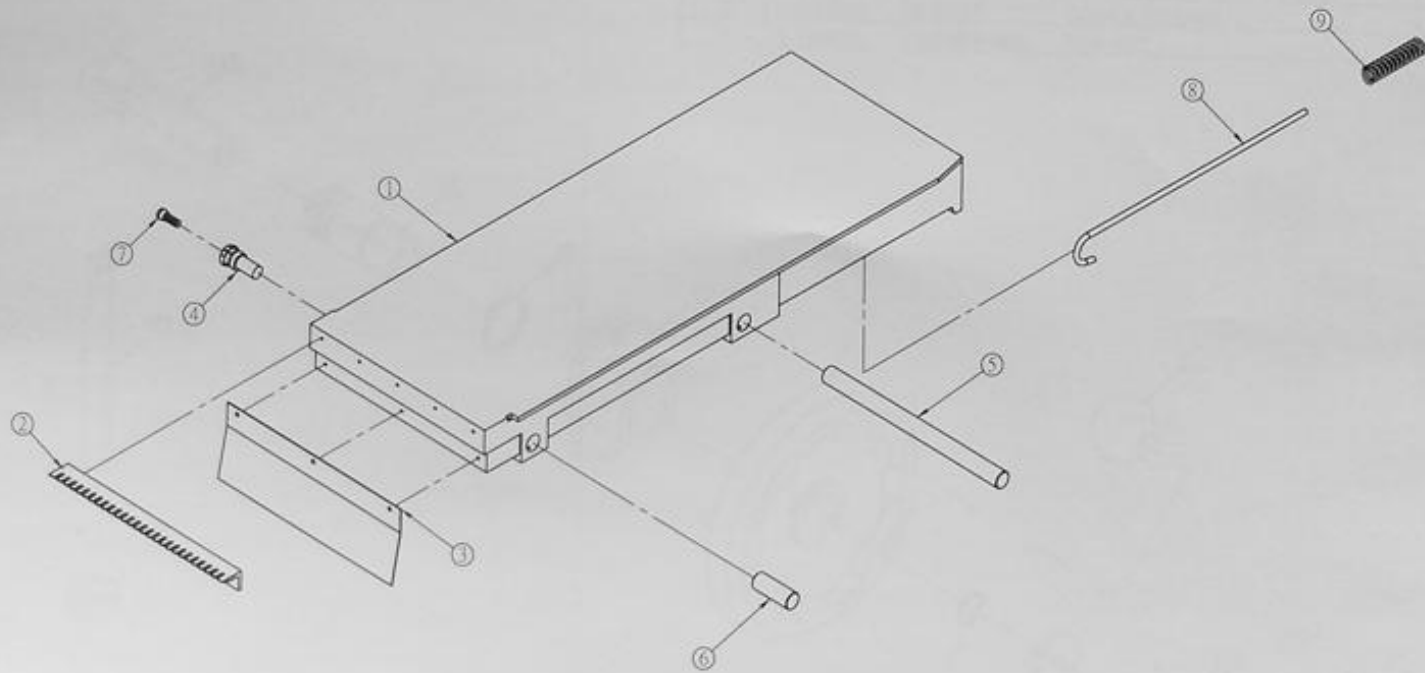

日期	2009/9/25	工程號	405S024
比例	1:6.5	機型圖號	405S024平板組立

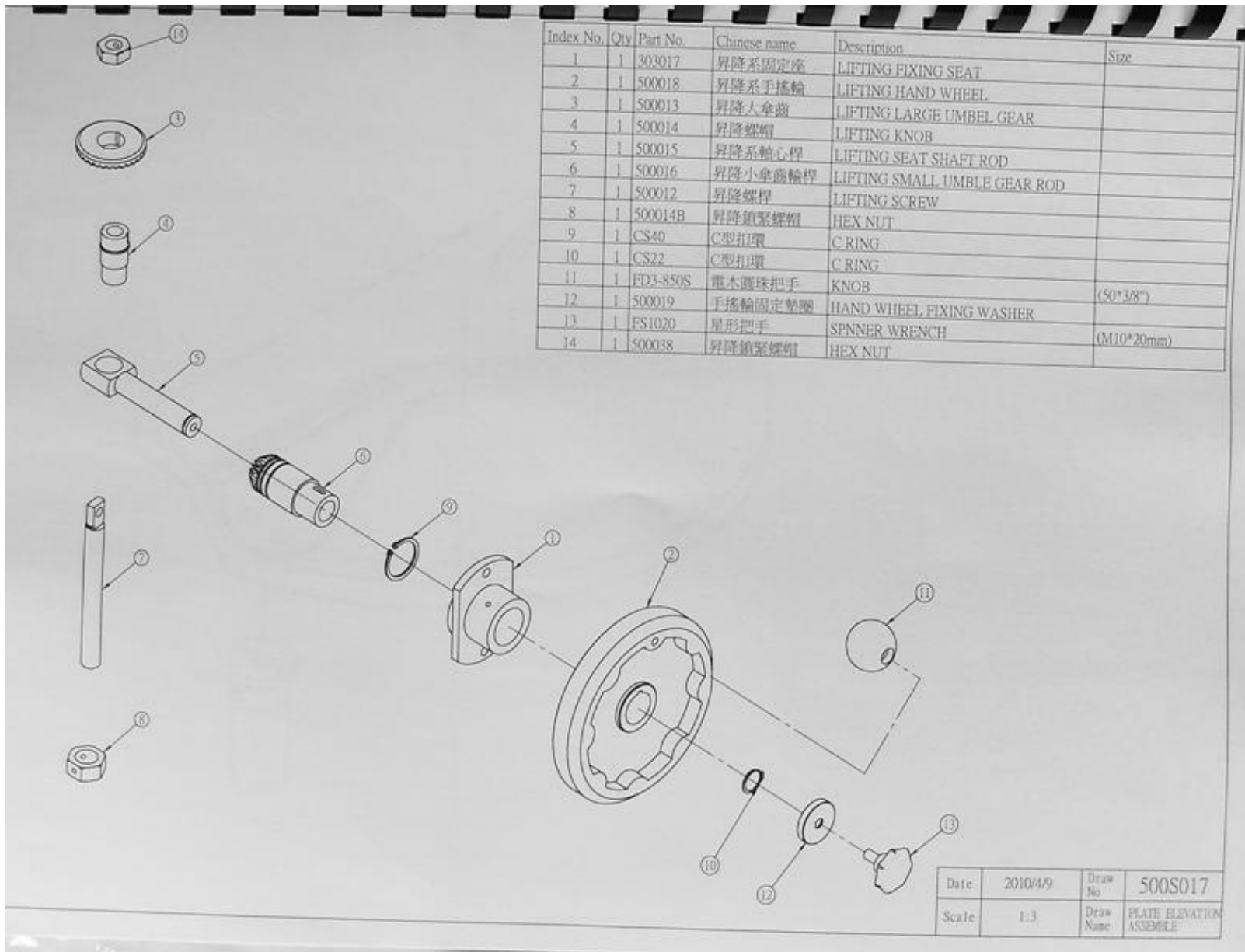

Index No.	Qty	Part No.	Chinese name	Description	Size
1	1	303017	昇降系固定座	LIFTING FIXING SEAT	
2	1	500018	昇降系手搖輪	LIFTING HAND WHEEL	
3	1	500013	昇降大傘齒	LIFTING LARGE UMBEL GEAR	
4	1	500014	昇降螺帽	LIFTING KNOB	
5	1	500015	昇降系軸心桿	LIFTING SEAT SHAFT ROD	
6	1	500016	昇降小傘齒輪桿	LIFTING SMALL UMBLE GEAR ROD	
7	1	500012	昇降螺桿	LIFTING SCREW	
8	1	500014B	昇降鎖緊螺帽	HEX NUT	
9	1	CS40	C型扣環	C RING	
10	1	CS22	C型扣環	C RING	
11	1	FD3-850S	電木圓珠把手	KNOB	
12	1	500019	手搖輪固定墊圈	HAND WHEEL FIXING WASHER	(50*38")
13	1	FS1020	星形把手	SPINNER WRENCH	(M10*20mm)
14	1	500038	昇降鎖緊螺帽	HEX NUT	

Date	2010/4/9	Draw No.	500S017
Scale	1:3	Draw Name	PLATE ELEVATION ASSEMBLE

Index No.	Qty	Part No.	Chinese name	Description	Size
2	1	500W049	回復組立	RETURN SHAFT	
1	1	405S045A	護刀鋁蓋	PROTECTION ALUMINUM COVER	

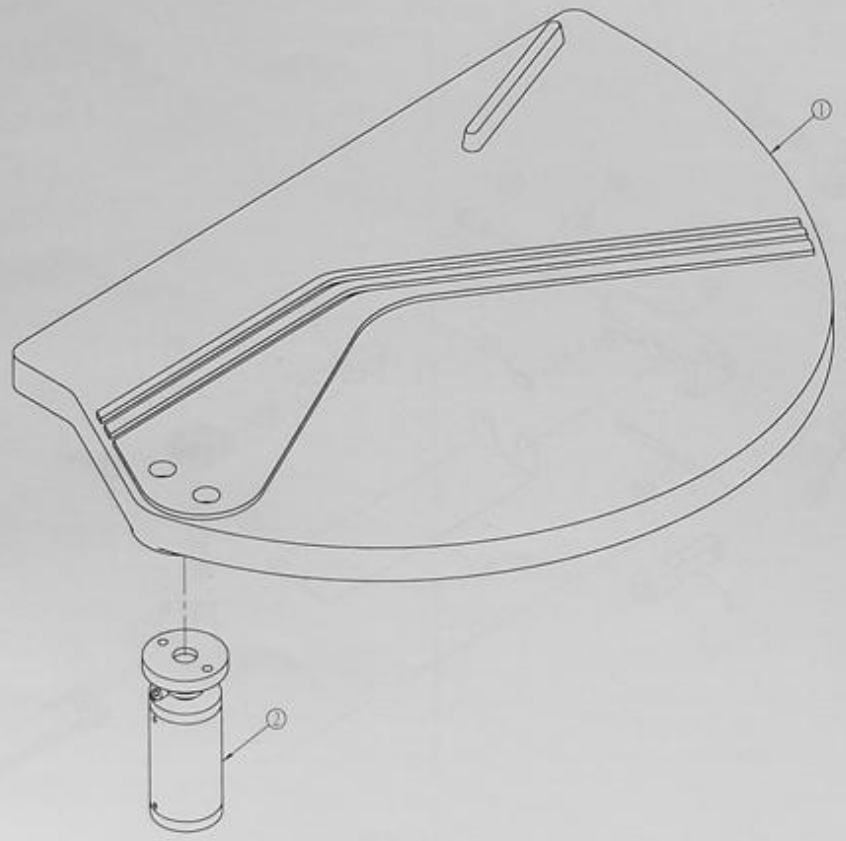

Date	2009/9/25	Draw No	405S045
Scale	1:2	Draw Name	405S045回復組立

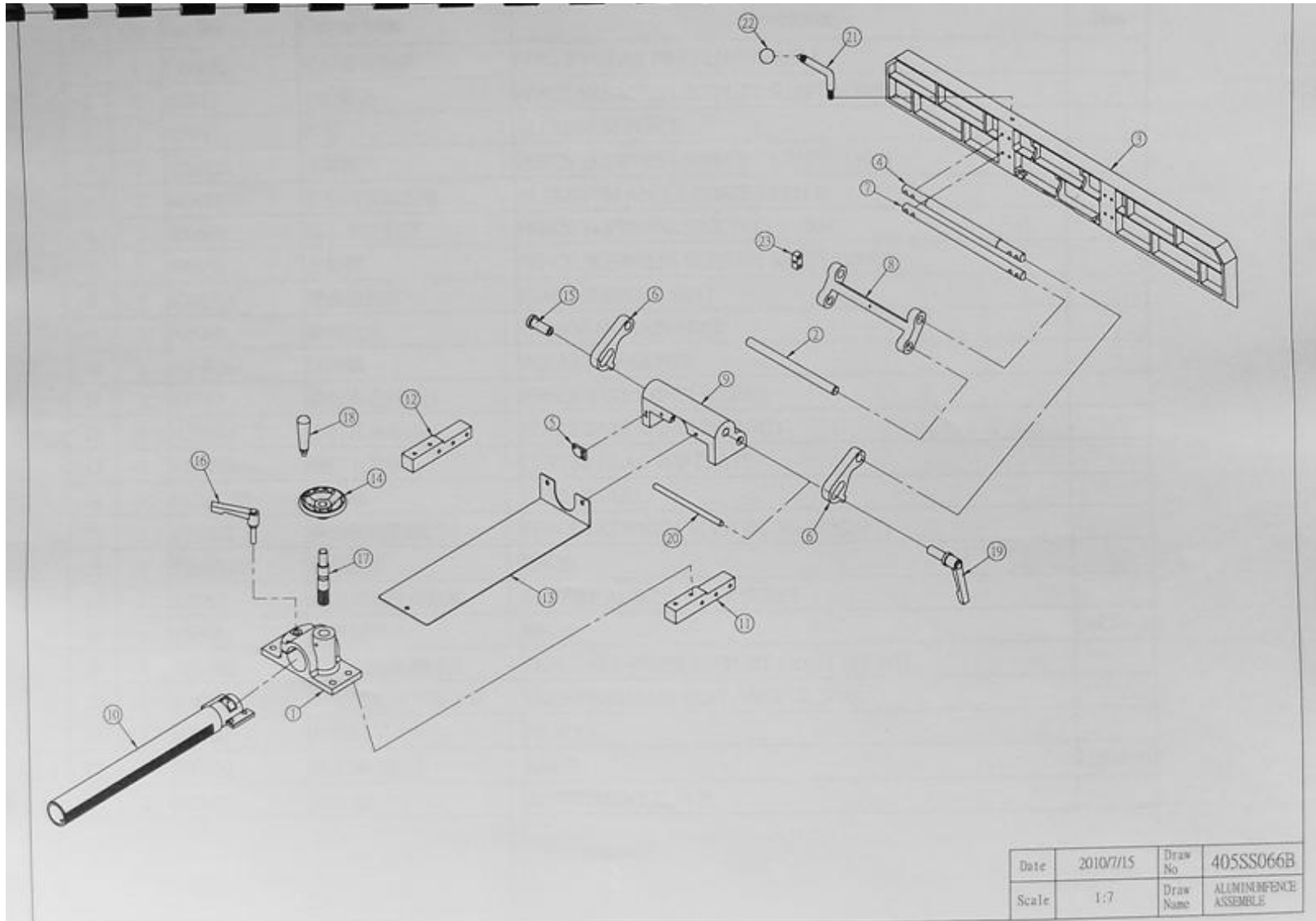

Index No.	Qty	Part No.	Chinese name	Description	Size
1	1	500062B	排出管滑動座	ROTARY GEAR PIPE SLINING SEAT	
2	1	405073	下扭動芯	FENCE SKEWNESS SUPPORT SHAFT(DOWN)	
3	1	405075	靠板	ALUMINUM FENCE	
4	1	405072A	支撐桿	FENCE SKEWNESS SUPPORT SHAFT(LONG)	
5	1	405083	靠板角度固定塊	ALUMINUM ANGLE FENCE FASTEN	
6	2	405065	偏心座扭動座	FENCE SKEWNESS SPECTACLE ARM	
7	1	405072	支撐桿	FENCE SKEWNESS SUPPORT SHAFT(LONG)	
8	1	405071A	雙連扭動座	FENCE SUPPORT SEAT	
9	1	405066	偏角主座	SKEWNESS MAIN SEAT	
10	1	405W063	排出管	ROTARY GEAR PIPE	
11	1	405084	靠板底座桿(左)	FENCE BASE SPINDLE(LEFT)	
12	1	405084A	靠板底座桿(右)	FENCE BASE SPINDLE(RIGHT)	
13	1	405060A	鉋仁上蓋板	CUTTER HEAD TOP PLATE	
14	1	HO3-4150	手搖輪	HAND WHEEL	
15	1	405080L	靠板座扭動軸(左)	FENCE SKEWNESS SUPPORT SHAFT(LEFT)	
16	1	TRSB1245	黑色把手	KNOB	
17	1	500061	排出管調整齒輪軸	ROTARY ADJMNT GEAR SHAFT	
18	1	YK3-8	塑膠把手	KNOB	(3/8")
19	1	405080R	靠板座扭動軸(右)	FENCE SKEWNESS SUPPORT SHAFT (RIGHT)	
20	1	405081	靠板扭動座支撐牙條	SKEWNESS MAIN SEAT ANCHOR IRON	
21	1	500100	角度把手	HANDOL	
22	1	FD1032	電木圓珠把手	KNOB	(32*M10)
23	1	500101	角度塊	ADJUSTMENT BLOCK	

Date	2010/7/15	Draw No.	405SS066B
Scale	1:50	Draw Name	ALUMINUM FENCE ASSEMBLE

Index No.	Qty	Part No.	Chinese name	Description	Size
1	1	20P010C	馬達皮帶輪	MOTOR BELT WHEEL	
2	1	500W083	馬達架	MOTOR PLATE	
3	1	MOTOR	馬達	MOTOR	
4	2	RA50	皮帶	A-BELT	

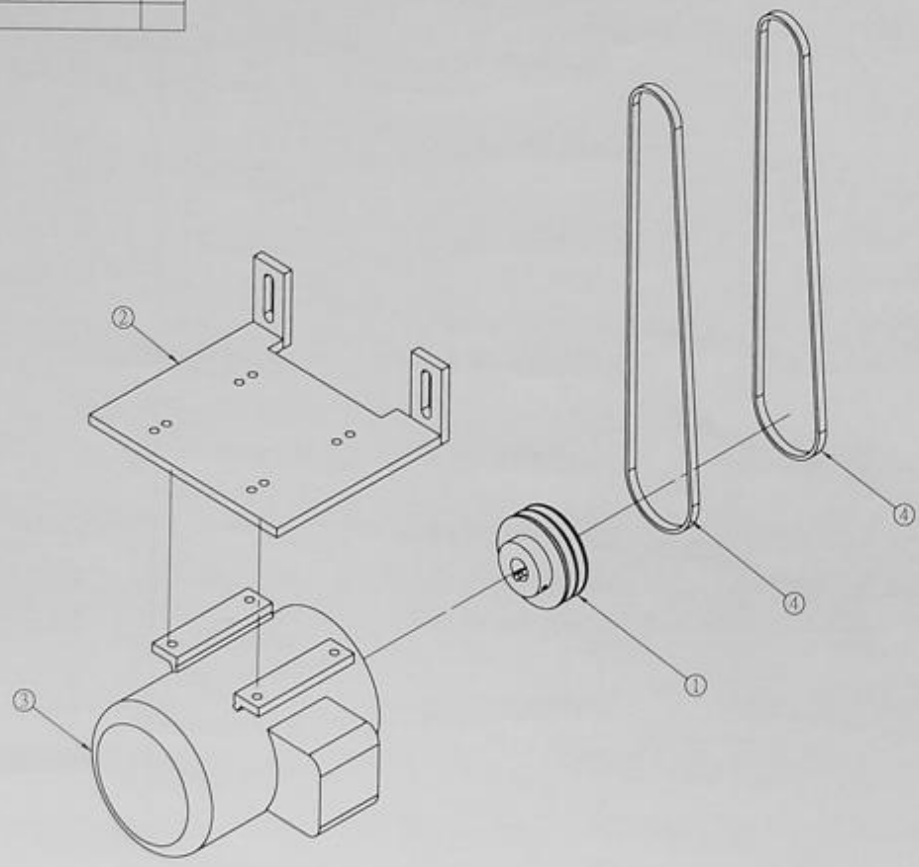

Date	2009/9/25	Draw No.	500S083A
Scale	1:4.5	Draw Name	MOTOR ASSEMBLY





# **LAGUNA**

2072 Alton Parkway. Irvine, CA 92606  
Ph: 800.234.1976 | [www.lagunatools.com](http://www.lagunatools.com)

Laguna Tools is not responsible for errors or omissions.  
Specifications subject to change. Machines may be shown with optional accessories.

© 2018, Laguna Tools, Inc. LAGUNA® and the LAGUNA Logo® are the  
registered trademarks of Laguna Tools, Inc. All rights reserved.