

16-32 - PARTS LIST - HEAD ASSEMBLY

#	PART NO.	DESCRIPTION	SIZE	QTY
1	71632-101	MOTOR	1-1/2HP, 115VOLT W/CORD	1
2	480BS-102	STRAIN RELIEF, MOTOR	7P-2	3
3	71632-103	MAIN CORD, MOTOR TO CONTROL BOX		1
4	480BS-104	KEY	3/16" SQ X 3/4"	2
5	480BS-105	NYLOCK NUT	5/16"-24	4
6	480BS-106	FLAT WASHER	5/16"	8
7	480BS-107	OILITE WASHER	5/16"	8
8	71632-108	MOTOR PLATE		1
9	71632-109	STUD		1
10	71632-110	HEX CAP SCREW	5/16"-18 X 1"	4
11	480BS-111	LOCK WASHER	3/8"	4
12	71632-112	SOCKET HEAD CAP SCREW	3/8"-16 X 3/4"	4
13	480BS-113	SET SCREW	1/4"-20 X 1/4"	5
14	480BS-114	COUPLING		2
15	480BS-115	COUPLING SPIDER		1
16	71632-116	DRO MOUNTING PLATE		1
17	480BS-117	PHILLIPS PAN HEAD SCREW	M4 X 0.7 X 6	5
18	71632-118	PHILLIPS PAN HEAD SCREW	M3 X 0.5 X 8	2
19	71632-119	SWITCH KNOB		1
20	480BS-120	KNOB		1
21	480BS-121	HEIGHT ADJUSTMENT HANDLE		1
22	480BS-122	NYLOCK NUT	5/8"-11	1
23	71632-123	HEIGHT ADJUSTMENT SCREW		1
24	71632-124	WASHER, WAVE	D17	1
25	480BS-125	THRUST BEARING	51103	1
26	71632-126	SHROUD		1
27	30-3028	STUD		4
28	71632-128	HEX CAP SCREW	3/8"-16 X 3/4"	8
29	480BS-129	FLAT WASHER	3/8"	8
30	480BS-130	HINGE		2
31	71632-131	DUST COVER		1
32	480BS-132	HANDLE		1
33	480BS-133	PAN HEAD MACHINE SCREW	#8 X 1/2"	4
34	480DS-134	LOCK WASHER	M3	2
35	480BS-135	DUST COVER LATCH		1
36	480DS-136	PHILLIPS FLAT HEAD SCREW	M3 X 0.5 X 10	2
37	71632-137	SANDING DRUM		1
38	480DS-138	HEX NUT	M3 X 0.5	2
39	480DS-139	INBOARD ABRASIVE FASTENER		1
40	480DS-140	OUTBOARD ABRASIVE FASTENER		1
41	71632-141	CARRIAGE BOLT	5/16"-18 X 3/4"	4
42	480DS-142	BEARING	6205LLU	2
43	480DS-143	C-RING	S25	2
44	71632-144	DRUM CARRIAGE		1
45	480BS-145	FLAT WASHER	1/4"	5
46	71632-146	ROUND SOCKET HEAD CAP SCREW	1/4"-20 X 3/4"	4
47	480BS-147	FLAT WASHER	5/16"	4
48	480DS-148	BEARING SEAT		2
49	480BS-149	HEX CAP SCREW W/ WASHER	#10-24 X 3/8"	2
50	480BS-150	DUST COVER CATCH		1
51	480BS-151	STUD		1
52	480BS-152	SPRING		1
53	71632-153	TENSION ROLLER		2
54	480BS-154	OILITE BUSHING		4
55	480BS-180	TENSION ROLLER BRACKET, INNER LEFT		2

16-32 - PARTS LIST - HEAD ASSEMBLY

56	480BS-156	SCREW	#8-32 X 1"	4
57	480BS-157	TENSION ROLLER SPRING		4
58	480BS-179	TENSION ROLLER BRACKET, INNER RIGHT		2
59	480BS-159	TENSION ROLLER BRACKET PAD		2
60	71632-160	BRACKET		2
61	480BS-161	PLATE		1
62	71632-162	BASE		1
63	480BS-163	QUICK ADJUSTING LEVER		1
64	480BS-164	ADJUSTING ROD		1
65	480BS-165	HEIGHT ADJUSTING PLATE		1
66	71632-166	ROUND SOCKET HEAD CAP SCREW	5/16"-18 X 3/4"	4
67	480BS-167	LOCK WASHER	5/16"	4
68	480BS-168	SPRING		3
69	480BS-169	NYLOCK NUT	1/4"-20	1
70	71632-170	SOCKET HEAD CAP SCREW	5/16"-18 X 1-1/2"	3
71	480DS-171	FLANGE NUT	5/16"	4
72	71632-172	SPRING		1
73	71632-173	LINKAGE		1
74	71632-174	RUBBER SLEEVE		1
75	71632-175	CAP		1
76	71632-176	ROD		1
77	71632-1110	PAN HEAD PHILLIPS SCREW	M4 X 0.7 X 12	4
78	71632-178	CYLINDER		1
79	71632-179	QUICK HANDLE		1
80	71632-180	SPACER		1
81	480BS-181	E-RING	E5	1
82	71632-182	NUT		1
83	71632-183	SOCKET HEAD CAP SCREW	M6 X 1.0 X 30	1
84	71632-184	SOCKET HEAD CAP SCREW	M6 X 1.0 X 15	1
85	71632-185	MICRO ADJUSTMENT/QUICK LABEL		1
86	480BS-186	MAINTENANCE LABEL		1
87	480BS-187	WARNING LABEL		1
88	71632-188	SET SCREW	#10-24 X 3/8"	1
89	71632-189	O-RING	P8	1
90	71632-190	SCREW	M5 X 0.8 X 12	3
91	71632-191	CONTROL BOX		1
92	71632-192	ON/OFF SWITCH		1
93	480DS-210	CONTROLLER		1
94	480BS-207	KNOB		1
95	71632-195	SPEED ADJUSTMENT LABEL		1
96	480DS-213	RECEPTACLE		1
97	480DS-203	POWER CORD		1
98	71632-198	SELF-TAPPING PAN HEAD SCREW	M3 X 0.5 X 10	2
99	480BS-214	SCREW	#10-32 X 1/2"	2
100	480BS-215	INT. TOOTH LOCK WASHER	#10	2
101	480BS-204	FLAT WASHER	5/16"	1
102	480BS-242	HEX NUT	5/16"-24	1
103	480BS-243	SLOTTED SET SCREW	#8-36 X 5/16"	1
104	71632-1104	HEX NUT	M4 X 0.7	4
105	71632-1105	HEX NUT	#10-32	2
106	71632-1106	COVER, BASE-CONTROL HOUSING		1
107	71632-1107	LCD MONITOR		1
108	71632-1108	DIGITAL READOUT ASSEMBLY		1
109	72550-197	PHILLIPS PAN HEAD SCREW	M4 X 0.7 X 12	2
110	71632-1110	BATTERY		2
111	71632-1111	ABRASIVE	#80 GRIT	1
112	71632-1112	NYLON WASHER	M3	1

16-32 - CONVEYOR AND MOTOR

#	PART NO.	DESCRIPTION	SIZE	QTY
1	71632-201	CONVEYOR MOTOR	90 VDC	1
2	480BS-204	FLAT WASHER	5/16"	4
3	480BS-205	SOCKET HEAD CAP SCREW	#10-32 X 1/2"	4
4	480BS-206	TRACKER KIT		2
5	71632-205	MOTOR MOUNTING PLATE		1
6	480BS-113	SET SCREW	1/4"-20 X 1/4"	2
7	480BS-224	HEX CAP SCREW	1/4"-20 X 3/4"	5
8	480BS-154	OILITE BUSHING		3
9	71632-209	ROLLER, DRIVEN		1
10	480BS-167	LOCK WASHER	5/16"	4
11	71632-211	ROLLER, DRIVE		1
12	480BS-237	DRIVE ROLLER SUPPORT BRACKET		1
13	71632-213	CONVEYOR BED		1
14	480BS-239	SOCKET HEAD CAP SCREW	1/4"-20 X 3/4"	4
15	71632-215	CONVEYOR BELT (NOT SHOWN)		1
16	480BS-245	HEX NUT	5/16"-18	2
17	71632-217	FLAT HEAD PHILLIPS SCREW	1/4"-20 X 3/4"	1
18	480BS-227	TAKE UP SLIDE BRACKET		2
19	480BS-234	TAKE UP BASE BRACKET		2
20	480BS-225	WAVE WASHER	1/4"	4
21	480BS-145	FLAT WASHER	1/4"	2
22	480BS-233	ROUND HEAD SLOTTED SCREW	1/4"-20 X 1-3/4"	2
23	480BS-232	INT. TOOTH LOCK WASHER	1/4"	2
24	480BS-230	WRENCH		2
25	480BS-231	HEX NUT	1/4"-20	2
26	480BS-247	HEX CAP SCREW W/ WASHER	1/4"-20X1/2"	6

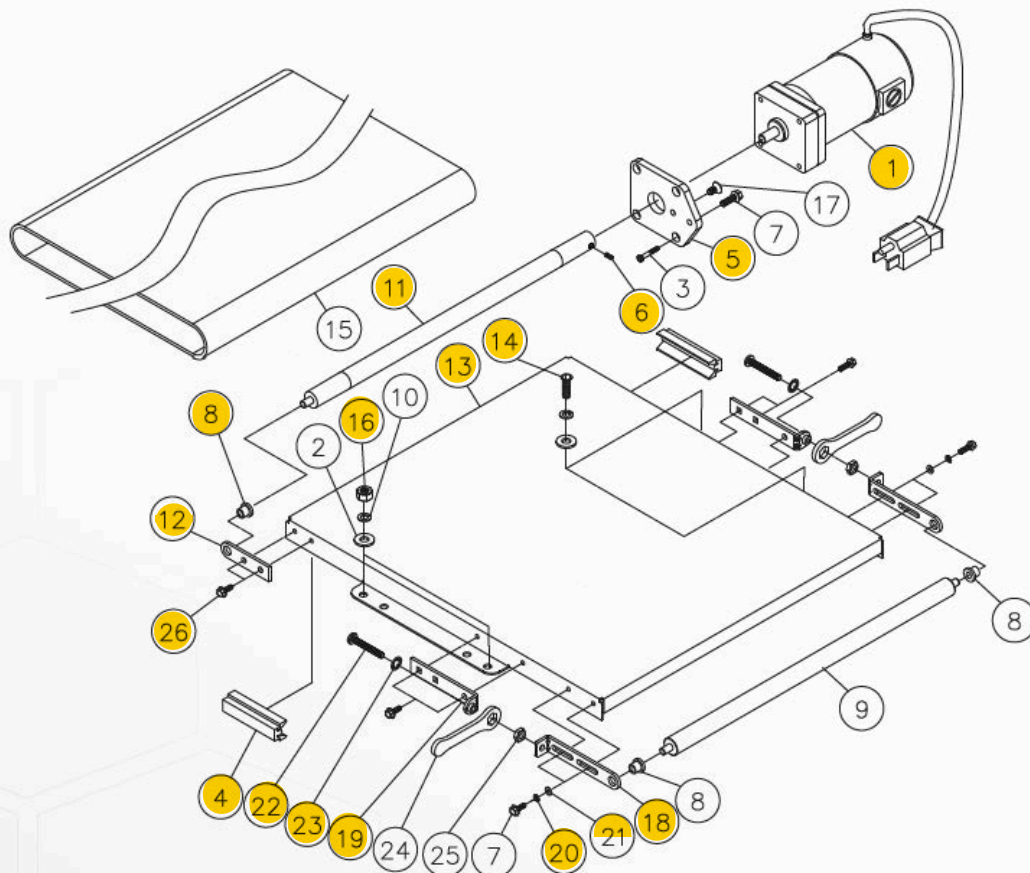

16-32 - OPEN STAND ASSEMBLY

#	PART NO.	DESCRIPTION	SIZE	QTY
1	480BS-501	LEG, LEFT		2
2	480BS-502	LEG, RIGHT (WITH TOOL HOLDER)		2
3	71632-303	TOP CROSS BRACE, LONG		2
4	71632-304	TOP CROSS BRACE, SHORT		2
5	71632-305	LOWER CROSS BRACE RAIL, LONG		2
6	71632-306	LOWER CROSS BRACE RAIL, SHORT		2
7	480BS-507	FLANGE NUT	5/16"	8
8	480BS-508	LEVELING FOOT		4
9	480BS-129	FLAT WASHER	3/8"	8
10	480BS-509	HEX NUT	3/8"-16	8
11	480BS-506	CARRIAGE BOLT	5/16"-18 X 5/8"	24

